

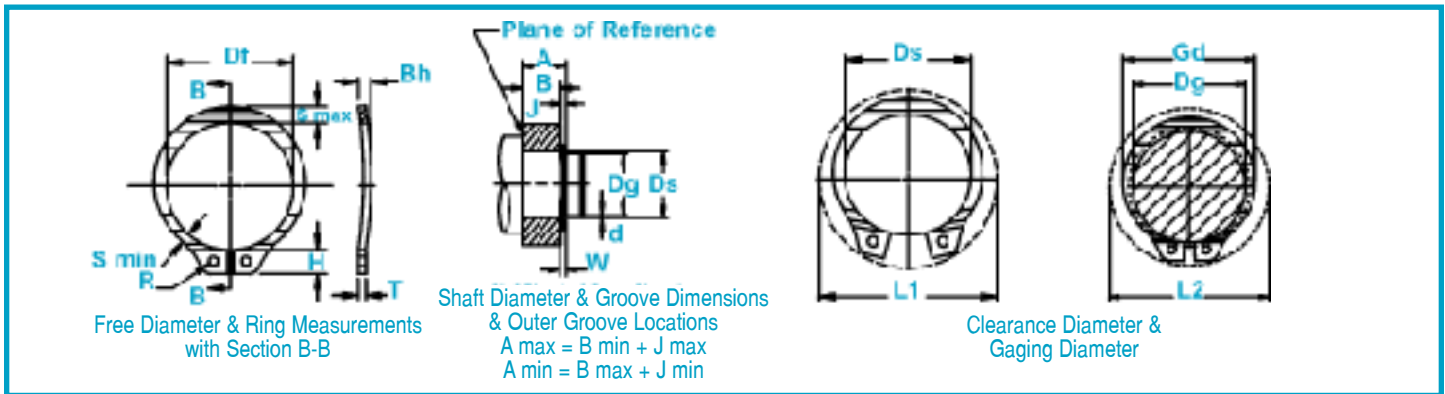

BSH Shaft Rings

Axially Assembled, External Bowed

Once snapped into the groove, bowed rings exert a force or a "preload" on the retained parts for the range specified.



RING NO.	SHAFT Diameter			GROOVE SIZE			RING SIZE & WEIGHT						CLEAR. DIA.			THRUST LD. (lbs.)			
	Ds DEC	Ds FRACT	Ds mm	Dg	W	idth	Depth	Free Diameter		Thickness ***		Bow Height		Wght. Per 1000 Pcs.	Ex-panded over shaft	Released in groove	Sqr. Corner	THRUST LD. (lbs.)	
								Tol.	d	Df	T	Bh	L1						L2
BSH-25	.250	1/4	6.4	.230	±.0015	.040	.010	.225	+.002	.025	.047	.21	.45	.43	599	175			
BSH-27	.276	-	7.0	.255		.040	.010	.250		.025	.047	.23	.48	.46	660	195			
BSH-28	.281	9/32	7.1	.261		.040	.010	.256		.025	.047	.24	.49	.47	670	200			
BSH-31	.312	5/16	7.9	.290		.040	.011	.281		.025	.047	.27	.54	.52	751	240			
BSH-34	.344	11/32	8.7	.321		.040	.011	.309		.025	.047	.31	.57	.55	812	265			
BSH-35	.354	-	9.0	.330	±.002	.040	.012	.320	+.002	.025	.047	.35	.59	.57	832	300			
BSH-37	.375	3/8	9.5	.352	.002*	.040	.012	.338	-.005	.025	.047	.39	.61	.59	883	325			
BSH-39	.394	-	10.0	.369		.040	.012	.354		.025	.047	.42	.62	.60	954	335			
BSH-40	.406	13/32	10.3	.382		.040	.012	.366		.025	.047	.43	.63	.61	964	350			
BSH-43	.438	7/16	11.1	.412		.040	.013	.395		.025	.047	.50	.66	.64	1035	400			
BSH-46	.469	15/32	11.9	.443		.040	.013	.428		.025	.047	.54	.68	.66	1117	450			
BSH-50	.500	1/2	12.7	.468		.055	.016	.461		.035	.063	.91	.77	.74	1675	550			
BSH-55	.551	-	14.0	.519	±.002	.055	.016	.509		.035	.063	.90	.81	.78	1827	600			
BSH-56	.562	9/16	14.3	.530	.004*	.055	.016	.521		.035	.063	1.1	.82	.79	1878	650			
BSH-59	.594	19/32	15.1	.559		.055	.017	.550		.035	.063	1.2	.86	.83	1979	750			
BSH-62	.625	5/8	15.9	.588		.055	.018	.579		.035	.063	1.3	.90	.87	2091	800			
BSH-66	.669	-	17.0	.629		.055	.020	.621		.035	.063	1.4	.93	.89	2233	950			
BSH-66	.672	43/64	17.1	.631		.055	.020	.621		.035	.063	1.4	.93	.89	2233	950			
BSH-68	.688	11/16	17.5	.646		.062	.021	.635	+.005	.042	.073	1.8	1.01	.97	3451	1000			
BSH-75	.750	3/4	19.0	.704	±.003	.062	.023	.693	-.010	.042	.073	2.1	1.09	1.05	3756	1200			
BSH-78	.781	25/32	19.8	.733	.004*	.062	.024	.722		.042	.073	2.2	1.12	1.08	3959	1300			
BSH-81	.812	13/16	20.6	.762		.062	.025	.751		.042	.073	2.5	1.15	1.10	4060	1450			
BSH-87	.875	7/8	22.2	.821		.062	.027	.810		.042	.073	2.8	1.21	1.16	4365	1650			
BSH-93	.938	15/16	23.8	.882		.062	.028	.867		.042	.073	3.1	1.34	1.29	4720	1850			
BSH-98	.984	63/64	25.0	.926		.062	.029	.910		.042	.073	3.5	1.39	1.34	4923	2000			
BSH-100	1.000	1	25.4	.940		.062	.030	.925		.042	.073	3.6	1.41	1.35	5024	2100			
BSH-102	1.023	-	26.0	.961		.062	.031	.946		.042	.073	3.9	1.43	1.37	5126	2250			
BSH-106	1.062	1-1/16	27.0	.998		.070	.032	.982		.050	.085	4.8	1.50	1.44	6293	2400			
BSH-112	1.125	1-1/8	28.6	1.059		.070	.033	1.041		.050	.085	5.1	1.55	1.49	6699	2600			
BSH-118	1.188	1-3/16	30.2	1.118		.070	.035	1.098		.050	.085	5.6	1.61	1.54	7105	2950			
BSH-125	1.250	1-1/4	31.7	1.176		.070	.037	1.156		.050	.085	5.9	1.69	1.62	7460	3250			
BSH-131	1.312	1-5/16	33.3	1.232		.070	.040	1.214	+.010	.050	.085	6.8	1.75	1.67	7866	3700			
BSH-137	1.375	1-3/8	34.9	1.291	±.004	.070	.042	1.272	-.015	.050	.085	7.2	1.80	1.72	8222	4100			
BSH-143	1.438	1-7/16	36.5	1.350	.005*	.070	.044	1.333		.050	.085	8.1	1.87	1.79	8628	4500			
BSH-150	1.500	1-1/2	38.1	1.406		.070	.047	1.387		.050	.085	9.0	1.99	1.90	8932	5000			
BSH-162	1.625	1-5/8	41.3	1.529	±.005	.096	+.005	.048	1.503	+.013	.062	±.003	.115	±.015	13.2	2.17	2.08	12028	5500
BSH-175	1.750	1-3/4	44.4	1.650	.005*	.096	-.000	.050	1.618	-.020	.062		.115		15.3	2.31	2.21	12992	6200

*F.I.M. (FULL INDICATOR MOVEMENT)-MAXIMUM ALLOWABLE DEVIATION OF CONCENTRICITY BETWEEN GROOVE AND SHAFT.

† BASED ON HOUSINGS/SHAFTS MADE OF COLD ROLLED STEEL. FOR AN EXPLANATION OF FORMULAS USED TO DERIVE THRUST LOAD AND OTHER PERFORMANCE DATA, CONTACT THE ROTOR CLIP ENGINEERING DEPT.

***FOR PLATED RINGS, ADD .002" TO THE LISTED MAXIMUM THICKNESS.

HARDNESS RANGES: STAINLESS STEEL RINGS (PH 15-7MO)

RING TYPE	SIZE RANGE	SCALE	ROCKWELL HARDNESS
BSH	25-81	30N	63-69.5
	87+	C	44-51

For technical assistance call 1-800-55-ROTOR

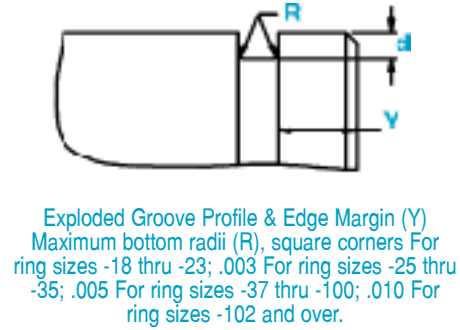
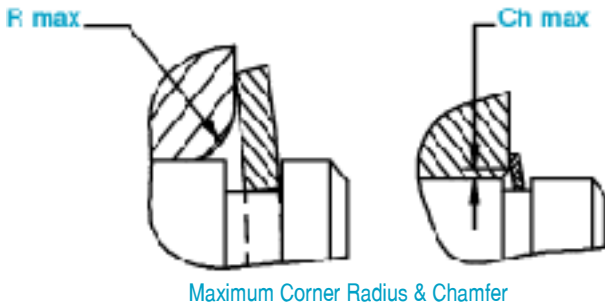

RING NO.	DISTANCE Outer groove wall to face of retained part		TAKE-UP Resilient take-up of tolerances	FORCE Needed to flatten rings	ALLOWABLE CORNER RADII & CHAMFERS		MAX. LOAD w/ R max or h max (in lbs.)	EDGE MARGIN	LUG HEIGHT		MAXIMUM SECTION		MINIMUM SECTION		HOLE DIAMETER		GAGING DIA.	R.P.M LIMITS Standard material
	J min	J max			J max	J min			lbs.	R max	Ch max	P'r (lbs.)	Y	H	Tol.	S max		
BSH-25	.030	.038	.008	50	.018	.011	470	.030	.080	±.003	.035	±.003	.025	±.003	.041	+.010 -.002	.290	80000
BSH-27	.030	.038		50	.0175	.0105	470	.031	.081		.035		.024		.041		.315	76000
BSH-28	.030	.038		50	.020	.012	470	.030	.080		.038		.0255		.041		.326	74000
BSH-31	.030	.038		50	.020	.012	470	.033	.087		.040		.026		.041		.357	70000
BSH-34	.030	.038		45	.021	.0125	470	.033	.087		.042		.0265		.041		.390	64000
BSH-35	.030	.038		45	.023	.014	470	.036	.087		.046		.029		.041		.405	62000
BSH-37	.030	.038		45	.026	.0155	470	.036	.088		.050		.0305		.041		.433	60000
BSH-39	.030	.038		40	.027	.016	470	.037	.087		.052		.031		.041		.452	56500
BSH-40	.030	.038		40	.0285	.017	470	.036	.087		.054		.033		.041		.468	55000
BSH-43	.030	.038		35	.029	.0175	470	.039	.088		.055		.033		.041		.501	50000
BSH-46	.030	.038		35	.031	.018	470	.039	.088		.060		.035		.041		.540	42000
BSH-50	.042	.053		90	.034	.020	910	.048	.108		.065		.040		.047		.574	40000
BSH-55	.042	.053		85	.027	.0165	910	.048	.108		.053		.036		.047		.611	36000
BSH-56	.042	.053		80	.038	.023	910	.048	.108		.072		.041		.047		.644	35000
BSH-59	.042	.053	70	.0395	.0235	910	.052	.109	.076	.043	.047	.680	32000					
BSH-62	.042	.053	60	.0415	.025	910	.055	.110	.080	.045	.047	.715	30000					
BSH-66	.042	.053	50	.040	.024	910	.060	.110	.082	.043	.047	.756	29000					
BSH-66	.042	.053	50	.040	.024	910	.060	.110	.082	.043	.047	.758	29000					
BSH-68	.049	.060	70	.042	.025	1340	.063	.136	.084	.048	.052	.779	28000					
BSH-75	.049	.060	65	.046	.0275	1340	.069	.136	.092	.051	.052	.850	26500					
BSH-78	.049	.060	60	.047	.028	1340	.072	.136	.094	.052	.052	.883	25500					
BSH-81	.049	.060	55	.047	.028	1340	.075	.136	.096	.054	.052	.914	24500					
BSH-87	.049	.060	45	.051	.035	1340	.081	.137	.104	.057	.052	.987	23000					
BSH-93	.049	.060	40	.055	.033	1340	.084	.166	.110	.063	.078	1.054	21500					
BSH-98	.049	.060	40	.056	.0335	1340	.087	.167	.114	.0645	.078	1.106	20500					
BSH-100	.049	.060	35	.057	.034	1340	.090	.167	.116	.065	.078	1.122	20000					
BSH-102	.049	.060	35	.058	.035	1340	.093	.168	.118	.066	.078	1.147	19500					
BSH-106	.057	.068	60	.060	.036	1950	.096	.181	.122	.069	.078	1.192	19000					
BSH-112	.057	.068	55	.063	.038	1950	.099	.182	.128	.071	.078	1.261	18800					
BSH-118	.057	.068	50	.064	.0385	1950	.105	.182	.132	.072	.078	1.325	18000					
BSH-125	.057	.068	45	.068	.041	1950	.111	.183	.140	.076	.078	1.396	17000					
BSH-131	.057	.068	40	.068	.041	1950	.120	.183	.146	.0765	.078	1.458	16500					
BSH-137	.057	.068	35	.072	.043	1950	.126	.184	.152	.082	.078	1.529	16000					
BSH-143	.057	.068	30	.076	.045	1950	.132	.184	.160	.086	.078	1.600	15000					
BSH-150	.057	.068	30	.079	.047	1950	.141	.214	.168	.091	.120	1.668	14800					
BSH-162	.069	.094	55	.087	.052	3000	.144	.235	.180	.097	.125	1.812	13200					
BSH-175	.069	.094	50	.091	.054	3000	.150	.237	.188	.101	.125	1.945	12200					

LARGER SIZES MAY BE AVAILABLE UPON REQUEST.

HARDNESS RANGES: BERYLLIUM COPPER RINGS

RING TYPE	SIZE RANGE	SCALE	ROCKWELL HARDNESS
BSH	18-23	15N	77-82*
	25-102	30N	54-62
	106+	C	34-43

*HARDNESS CAN NOT BE CHECKED WITH ANY DEGREE OF ACCURACY DIRECTLY ON THESE RINGS.

HARDNESS RANGES: CARBON STEEL RINGS (SAE 1060-1090)

RING TYPE	SIZE RANGE	SCALE	ROCKWELL HARDNESS
BSH	25-46	30N	69.5-73
	50-81	30N	66-71
	87-102	C	47-53
	106+	C	47-52