

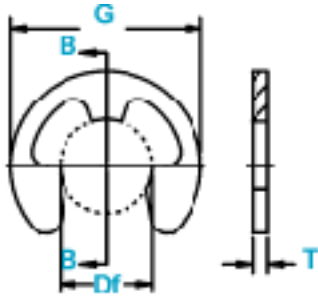

E Retaining Rings

Radially Assembled, External

The three prongs of this ring make contact with the bottom of the groove for effective retention of an assembly.



Free Diameter & Ring Measurements
With Section B-B

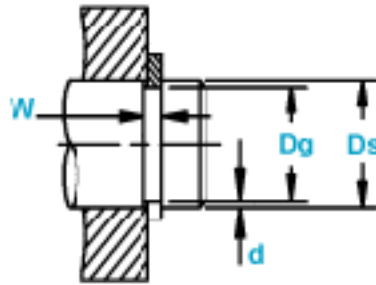

Shaft Diameter &
Groove Dimensions



Clearance Diameter
Installed In Groove

RING NO.	SHAFT DIAMETER D			GROOVE SIZE					RING SIZE & WEIGHT				CLEARANCE DIA.			THRUST LD. (lbs.)	
	Ds DEC	Ds FRAC	Ds mm	DIAMETER		WIDTH		DEPTH	FREE DIAMETER			THICKNESS***	Weight Per 1000 pcs.	Free outside dia. REF.	Installed in groove	Sqr. corner	abutment
				Dg	Tol.	W	Tol.		d	Df	Tol.						
**E-4	.040	-	1.0	.026	+.002	.012	+.002	.007	.025	+.001	.010	±.001	.009	.079	.090	13	6
E-6	.062	1/16	1.6	.052	+.002	.012	+.002	.005	.051	-.003	.010	±.001	.030	.156	.165	20	7
SE-6	.062	1/16	1.6	.052	-.000	.012	-.000	.005	.051		.010		.028	.140	.150	20	7
YE-6	.062	1/16	1.6	.052	*.0015	.023		.005	.051		.020		.094	.187	.200	41	7
SE-9	.094	3/32	2.4	.074		.020		.010	.069	+.002-.003	.015		.10	.230	.245	46	20
E-9	.094	3/32	2.4	.074		.020		.010	.073		.015		.058	.187	.200	46	20
SE-11	.110	7/64	2.8	.079		.020		.015	.076		.015		.31	.375	.390	61	40
SE-12	.125	1/8	3.2	.095		.029		.015	.094		.025		.12	.214	.225	110	45
E-12	.125	1/8	3.2	.095		.020		.015	.094		.015		.087	.230	.240	66	45
SE-14	.140	9/64	3.6	.102		.020		.019	.100		.015		.060	.203	.215	76	60
YE-14	.140	9/64	3.6	.110		.020		.015	.108		.015		.10	.250	.265	76	45
E-14	.140	9/64	3.6	.105	+.002	.029		.017	.102	+.001	.025	±.002	.21	.270	.285	173	60
SE-15	.156	5/32	4.0	.118	-.000	.046		.019	.116	-.003	.042		.76	.375	.390	300	70
E-15	.156	5/32	4.0	.116	*.002	.029		.020	.114		.025		.21	.282	.295	178	75
SE-17	.172	11/64	4.4	.127		.029		.022	.125		.025		.24	.312	.325	183	90
SE-18	.188	3/16	4.8	.125		.029		.031	.122		.025		.45	.375	.39	203	135
YE-18	.188	3/16	4.8	.147		.029		.020	.145		.025		.70	.470	.485	193	90
ZE-18	.188	3/16	4.8	.125		.029		.031	.122		.025		1.05	.550	.565	203	135
E-18	.188	3/16	4.8	.147		.029		.020	.145		.025		.29	.335	.35	193	90
SE-21	.219	7/32	5.6	.188		.029		.015	.185		.025		.47	.437	.45	228	75
E-25	.250	1/4	6.3	.210		.029		.020	.207		.025		.76	.527	.54	259	115
SE-31	.312	5/16	7.9	.250	+.003	.029	+.003	.031	.243	+.002	.025		.57	.500	.52	330	225
YE-31	.312	5/16	7.9	.250	-.000	.029	-.000	.031	.243	-.004	.025		1.220	.670	.685	325	220
SE-37	.375	3/8	9.5	.306	*.004	.039		.034	.303		.035		1.050	.567	.587	680	300
E-37	.375	3/8	9.5	.303		.039		.036	.300		.035		1.5	.660	.68	700	315
E-43	.438	7/16	11.1	.343		.039		.047	.337		.035		1.5	.687	.71	842	480
SE-43	.438	7/16	11.1	.380		.039		.029	.375		.035		1.0	.600	.62	812	280
E-50	.500	1/2	12.7	.396		.046		.052	.392		.042		2.5	.800	.82	1127	600
E-62	.625	5/8	15.9	.485		.046		.070	.480		.042		3.2	.940	.96	1441	1050
SE-74	.750	3/4	19.0	.625		.056		.062	.616	+.003	.050		4.3	1.000	1.02	1979	1100
E-75	.750	3/4	19.0	.580		.056		.085	.574	-.005	.050		5.8	1.120	1.14	2030	1500
E-87	.875	7/8	22.2	.675		.056		.100	.668		.050		7.6	1.300	1.32	2385	2050
SE-98	.984	63/64	25.0	.835		.056		.074	.822		.050		9.2	1.500	1.53	2639	1750
SE-98	1.000	1	25.4	.835		.056		.082	.822		.050		9.2	1.500	1.53	2690	1900
SE-118	1.188	1-3/16	30.2	1.079	+.005	.068	+.004	.054	1.066	+.006	.062	±.003	11.3	1.626	1.67	3501	1500
SE-137	1.375	1-3/8	34.9	1.230	0.000 * .00	.068	-.000	.072	1.213	-.010	.062		15.4	1.875	1.92	4162	2350

LISTED GROOVE WIDTH (W) MINIMUM.

* F.I.M. (FULL INDICATOR MOVEMENT)- MAXIMUM ALLOWABLE DEVIATION OF CONCENTRICITY BETWEEN GROOVE AND SHAFT.

** AVAILABLE IN BERYLLIUM COPPER ONLY.

† BASED ON GROOVES MADE OF COLD ROLLED STEEL. FOR AN EXPLANATION OF FORMULAS USED TO DERIVE THRUST LOAD AND OTHER PERFORMANCE DATA CONTACT THE ROTOR CLIP ENGINEERING DEPARTMENT.

*** FOR PLATED RINGS, ADD .002" TO THE LISTED MAXIMUM THICKNESS. MAXIMUM THICKNESS WILL BE A MINIMUM OF .0002" LESS THAN THE

For technical assistance call **1-800-55-ROTOR**

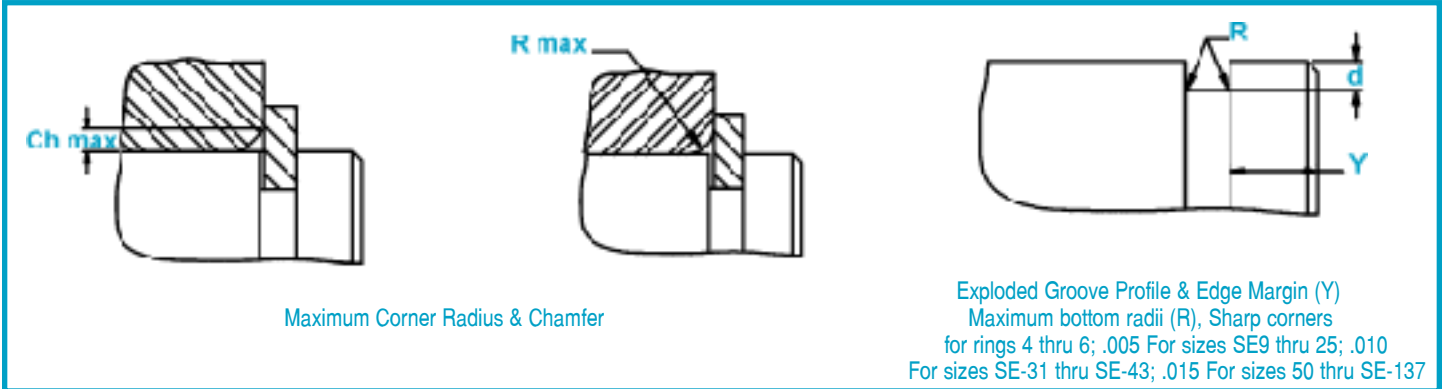

Maximum Corner Radius & Chamfer

Exploded Groove Profile & Edge Margin (Y)
Maximum bottom radii (R), Sharp corners
for rings 4 thru 6; .005 For sizes SE9 thru 25; .010
For sizes SE-31 thru SE-43; .015 For sizes 50 thru SE-137

RING NO.	ALLOWABLE CORNER RADII & CHAMFERS		MAX OAD w/ R max or Ch max (in lbs.)	EDGE MARGIN	R.P.M. LIMITS Standard material
	R max	Ch max			
**E-4	.015	.010	13	.014	40000
E-6	.030	.020	20	.010	40000
SE-6	.030	.020	20	.010	40000
YE-6	.035	.025	40	.010	40000
SE-9	.053	.040	45	.020	36000
E-9	.040	.030	45	.020	36000
SE-11	.080	.060	60	.030	35000
SE-12	.040	.030	108	.030	35000
E-12	.040	.030	65	.030	35000
SE-14	.029	.022	75	.038	32000
YE-14	.040	.030	75	.030	32000
E-14	.060	.045	170	.034	32000
SE-15	.080	.060	250	.038	31000
E-15	.060	.045	175	.040	31000
SE-17	.060	.045	180	.044	30000
SE-18	.060	.045	200	.062	30000
YE-18	.060	.045	190	.040	25000
ZE-18	.060	.045	200	.062	18000
E-18	.060	.045	190	.040	30000
SE-21	.060	.045	225	.030	26000
E-25	.060	.045	255	.040	25000
SE-31	.060	.045	325	.062	22000
YE-31	.060	.045	320	.062	15000
SE-37	.060	.045	680	.068	20000
E-37	.065	.050	690	.072	20000
E-43	.065	.050	830	.094	16500
SE-43	.050	.035	800	.058	16500
E-50	.080	.060	1110	.104	14000
E-62	.080	.060	1420	.140	12000
SE-74	.057	.042	1900	.124	11000
E-75	.085	.065	2000	.170	10500
E-87	.085	.065	2350	.200	9000
SE-98	.085	.065	2700	.148	6500
SE-98	.077	.057	2700	.164	6500
SE-118	.090	.070	3450	.108	5500
SE-137	.090	.070	4100	.144	4000

LARGER SIZES MAY BE AVAILABLE UPON REQUEST.

HARDNESS RANGES: STAINLESS STEEL RINGS (PH 15-7MO)

RING TYPE	SIZE RANGE	SCALE	ROCKWELL HARDNESS
E All	E6-SE6	15N	82.5-86*
	YE6-YE14	15N	82.5-86
	E14-SE31	30N	63-69.5
	E37+	C	44-51

*HARDNESS CAN NOT BE CHECKED WITH ANY DEGREE OF ACCURACY DIRECTLY ON THESE RINGS.

HARDNESS RANGES: CARBON STEEL RINGS (SAE 1060-1090)

RING TYPE	SIZE RANGE	SCALE	ROCKWELL HARDNESS
E All	E6-SE6	15N	84.5-87*
	YE6-YE14	15N	84.5-87
	E14-SE31	30N	66.5-71
	E37+	C	47-52

HARDNESS RANGES: BERYLLIUM COPPER RINGS

RING TYPE	SIZE RANGE	SCALE	ROCKWELL HARDNESS
E All	E4-SE6	15N	79-82*
	YE6-YE14	15N	79-82
	E14-SE31	30N	56.5-62
	E37+	C	37-43