

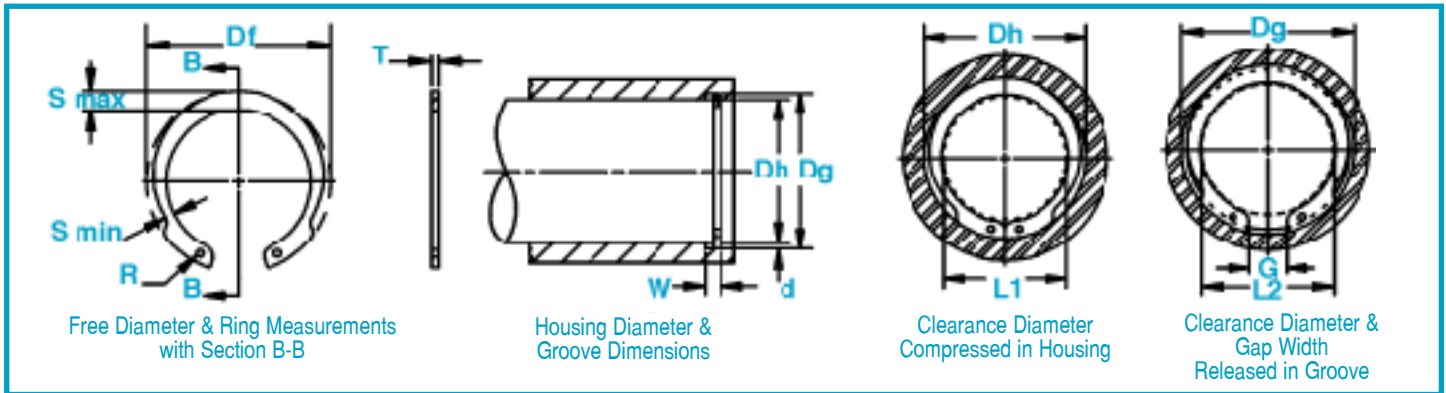

# HOI Housing Rings

## Axially Assembled, Internal

The inverted position of the lugs affords greater clearance than the basic internal retaining ring.



RING NO.	HOUSING			GROOVE SIZE			RING SIZE & WEIGHT				CLEARANCE DIA.		i THRUST LD. (lbs.) Sqr. Corner Abutment				
	DIAMETER			DIAMETER		WIDTH		DEPTH	FREE DIAMETER		THICKNESS***		Wght. Per 1000 Pcs.	Compressed in housing L1	Released in groove L2	Ring Safety Factor of 4 Pr	Groove Safety Factor of 2 Pg
	Dh DEC	Dh FRACT	Dh mm	Dg	Tol.	W	Tol.	d	Df	Tol.	T	Tol.					
HOI-62	.625	5/8	15.9	.665	±.002	.029		.020	.675		.025		0.7	.47	.51	1015	450
HOI-75	.750	3/4	19.0	.796	.004*	.039		.023	.808		.035		1.3	.56	.605	1675	600
HOI-81	.812	13/16	20.6	.862		.046	+.003	.025	.877	+.010	.042		2.0	.62	.665	2639	700
HOI-87	.875	7/8	22.2	.931	±.003	.046	-.000	.028	.944	-.005	.042		2.2	.65	.705	2893	850
HOI-93	.938	15/16	23.8	1.000	.004*	.046		.031	1.015		.042		2.8	.70	.755	3147	1000
HOI-100	1.000	1	25.4	1.066		.046		.033	1.081		.042		2.9	.75	.81	3350	1150
HOI-106	1.062	1-1/16	27.0	1.130		.056		.034	1.150		.050		3.8	.80	.87	4212	1250
HOI-112	1.125	1-1/8	28.6	1.197		.056		.036	1.217		.050		4.4	.86	.93	4466	1400
HOI-118	1.188	1-3/16	30.2	1.262		.056		.037	1.283	+.015	.050	±.002	4.9	.91	.98	4720	1600
HOI-125	1.250	1-1/4	31.7	1.330	±.004	.056		.040	1.351	-.010	.050		5.0	.97	1.05	4974	1750
HOI-131	1.312	1-5/16	33.3	1.396	.005*	.056		.042	1.418		.050		5.3	1.02	1.10	5227	1950
HOI-137	1.375	1-3/8	34.9	1.461		.056	+.004	.043	1.486		.050		5.9	1.08	1.16	5481	2100
HOI-143	1.438	1-7/16	36.5	1.528		.056	-.000	.045	1.552		.050		6.3	1.13	1.22	5735	2300
HOI-150	1.500	1-1/2	38.1	1.594		.056		.047	1.622		.050		6.8	1.18	1.27	5938	2500
HOI-156	1.562	1-9/16	39.7	1.658		.068		.048	1.688		.062		8.9	1.21	1.30	7714	2650
HOI-162	1.625	1-5/8	41.3	1.725		.068		.050	1.756		.062		10.4	1.27	1.37	8019	2850
HOI-168	1.688	1-11/16	42.9	1.792	±.005	.068		.052	1.823	+.020	.062		11.9	1.32	1.42	8374	3100
HOI-175	1.750	1-3/4	44.4	1.858	.005*	.068		.054	1.891	-.013	.062		11.8	1.38	1.49	8678	3300
HOI-187	1.875	1-7/8	47.6	1.989		.068		.057	2.025		.062		14.8	1.47	1.58	9287	3750
HOI-200	2.000	2	50.8	2.122		.068		.061	2.160		.062		17.4	1.55	1.67	9896	4300
HOI-206	2.062	2-1/16	52.4	2.186		.086		.062	2.224		.078		23.2	1.59	1.71	12840	4500
HOI-212	2.125	2-1/8	54.0	2.251	±.006	.086	+.005	.063	2.295		.078		24.3	1.65	1.77	13246	4700
HOI-237	2.375	2-3/8	60.3	2.517	.006*	.086	-.000	.071	2.567	+.025	.078	±.003	28.6	1.86	2.00	14718	5900
HOI-243	2.438	2-7/16	61.9	2.584		.086		.072	2.634	-.015	.078		30.6	1.91	2.05	15124	6200
HOI-250	2.500	2-1/2	63.5	2.648		.086		.074	2.700		.078		32.1	1.96	2.10	15530	6500
HOI-262	2.625	2-5/8	66.7	2.781		.103		.078	2.840		.093		45.6	2.06	2.21	19488	7200
HOI-275	2.750	2-3/4	69.8	2.914		.103		.082	2.975		.093		47.8	2.16	2.32	20300	7900
HOI-283	2.812	2-13/16	71.4	2.980		.103		.084	3.063		.093		49.5	2.21	2.37	20808	8300
HOI-283	2.835	-	72.0	3.006		.103		.086	3.063		.093		49.5	2.23	2.39	20808	8550
HOI-287	2.875	2-7/8	73.0	3.051		.103		.088	3.105	+.030	.093		50.1	2.26	2.43	21315	8900
HOI-300	3.000	3	76.2	3.182		.103		.091	3.245	-.020	.093		52.6	2.36	2.53	22229	9600
HOI-315	3.156	3-5/32	80.2	3.348		.120		.096	3.408		.109		69.4	2.50	2.69	27405	10600
HOI-325	3.250	3-1/4	82.5	3.446		.120		.098	3.509		.109		72.6	2.58	2.77	28217	11200
HOI-334	3.346	3-11/32	85.0	3.546		.120		.100	3.611		.109		75.6	2.67	2.87	29029	11700
HOI-350	3.500	3-1/2	88.9	3.710		.120		.105	3.780		.109		80.2	2.82	3.03	30349	12900
HOI-356	3.562	3-9/16	90.5	3.776		.120		.107	3.850		.109		82.4	2.88	3.09	30958	13400
HOI-400	4.000	4	101.6	4.240		.120		.120	4.350		.109		97.4	3.29	3.53	34713	16900

\*F.I.M. (FULL INDICATOR MOVEMENT)-MAXIMUM ALLOWABLE DEVIATION OF CONCENTRICITY BETWEEN GROOVE AND HOUSING.

i BASED ON HOUSING/SHAFTS MADE OF COLD ROLLED STEEL. FOR AN EXPLANATION OF FORMULAS USED TO DERIVE THRUST LOAD AND OTHER PERFORMANCE DATA, CONTACT THE ROTOR CLIP ENGINEERING DEPT.

\*\*\* FOR PLATED RINGS, ADD .002" TO THE LISTED MAXIMUM THICKNESS. MAXIMUM RING THICKNESS WILL BE A MINIMUM OF .0002" LESS THAN THE LISTED GROOVE WIDTH (W) MINIMUM.

# For technical assistance call 1-800-55-ROTOR

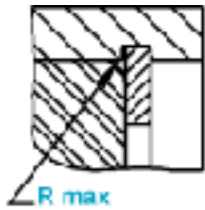

Allowable Corner Radius & Chamfer

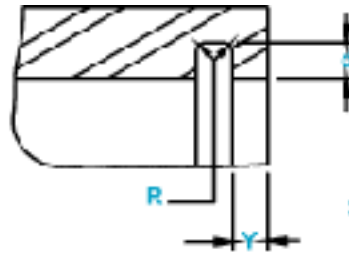
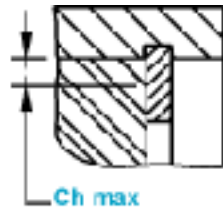

Exploded Groove Profile & Edge Margin (Y)  
Maximum bottom radii (R), .005 for ring sizes -62 thru -100; .010 for ring sizes -106 thru -400



Measuring Free Diameter (Df)  
HOI Series  
 $Df = D1 + 2(S \text{ max})$



Alternate Design  
Manufacturer's  
Option

RING NO.	MAXIMUM SECTION Including lug		MINIMUM SECTION		HOLE DIAMETER		GAP WIDTH Ring in groove	Allowable Corner Radii & Chamfers			MAX LOAD W/R Max or Ch Max	EDGE MARGIN
	S max	Tol.	S min.	Tol.	R	Tol.		R max	Ch max	P'r		
HOI-62	.072	±.004	.036	±.004	.030	+.010 -.002	.16	.042	.028	400	.060	
HOI-75	.085	±.005	.042	±.005	.042		.165	.050	.031	850	.069	
HOI-81	.092		.044		.042		.18	.054	.034	1250	.075	
HOI-87	.099		.047		.042		.19	.057	.036	1250	.084	
HOI-93	.106		.051		.042		.22	.060	.038	1250	.093	
HOI-100	.113		.054		.042		.235	.064	.040	1250	.099	
HOI-106	.120		.057		.050		.22	.069	.043	1800	.102	
HOI-112	.123		.059		.050		.245	.070	.044	1800	.108	
HOI-118	.126		.060		.050		.26	.071	.045	1800	.111	
HOI-125	.129		.061		.050		.28	.071	.045	1800	.120	
HOI-131	.132		.063		.050	.29	.072	.045	1800	.126		
HOI-137	.135	.065	.050	.33	.074	.046	1800	.129				
HOI-143	.144	.069	.076	.35	.079	.050	1800	.135				
HOI-150	.148	.070	.076	.33	.081	.051	1800	.141				
HOI-156	.158	.074	.076	.36	.088	.055	2900	.144				
HOI-162	.162	.077	.076	.385	.090	.056	2900	.150				
HOI-168	.166	.079	.076	.405	.091	.057	2900	.156				
HOI-175	.170	.082	.076	.42	.093	.058	2900	.162				
HOI-187	.188	.090	.076	.44	.105	.066	2900	.171				
HOI-200	.208	.100	.076	.48	.118	.074	2900	.183				
HOI-206	.218	.106	.094	.485	.125	.078	4600	.186				
HOI-212	.223	.108	.094	.49	.128	.080	4600	.189				
HOI-237	.243	.115	.094	.55	.138	.086	4600	.213				
HOI-243	.248	.117	.094	.57	.141	.088	4600	.216				
HOI-250	.254	.120	.094	.59	.144	.090	4600	.222				
HOI-262	.266	.128	.109	.60	.150	.094	6700	.234				
HOI-275	.278	.134	.109	.63	.157	.098	6700	.246				
HOI-283	.286	.139	.109	.61	.162	.102	6700	.252				
HOI-283	.286	.139	.109	.67	.162	.102	6700	.258				
HOI-287	.290	.139	.109	-	.162	.101	6700	.264				
HOI-300	.302	.143	.109	.705	.169	.106	6700	.273				
HOI-315	.314	.149	.125	.76	.174	.109	9000	.288				
HOI-325	.318	.151	.125	-	.176	.110	9000	.294				
HOI-334	.321	.155	.125	.81	.177	.111	9000	.300				
HOI-350	.324	.154	.125	.84	.175	.110	9000	.315				
HOI-356	.326	.155	.125	.86	.175	.110	9000	.321				
HOI-400	.338	.161	.125	.93	.174	.108	9000	.360				

HARDNESS RANGES: STAINLESS STEEL RINGS (PH 15-7MO)

RING TYPE	SIZE RANGE	SCALE	ROCKWELL HARDNESS
HOI	62-100	30N	63-69.5
	106+	C	44-51

HARDNESS RANGES: CARBON STEEL RINGS (SAE 1060-1090)

RING TYPE	SIZE RANGE	SCALE	ROCKWELL HARDNESS
HOI	62 & 75	30N	67.5-72
	81-100	30N	66-71
	106-343	C	47-52
	350+	C	45-50

HARDNESS RANGES: BERYLLIUM COPPER RINGS

RING TYPE	SIZE RANGE	SCALE	ROCKWELL HARDNESS
HOI	62-100	30N	56.5-62
	106+	C	37-43