

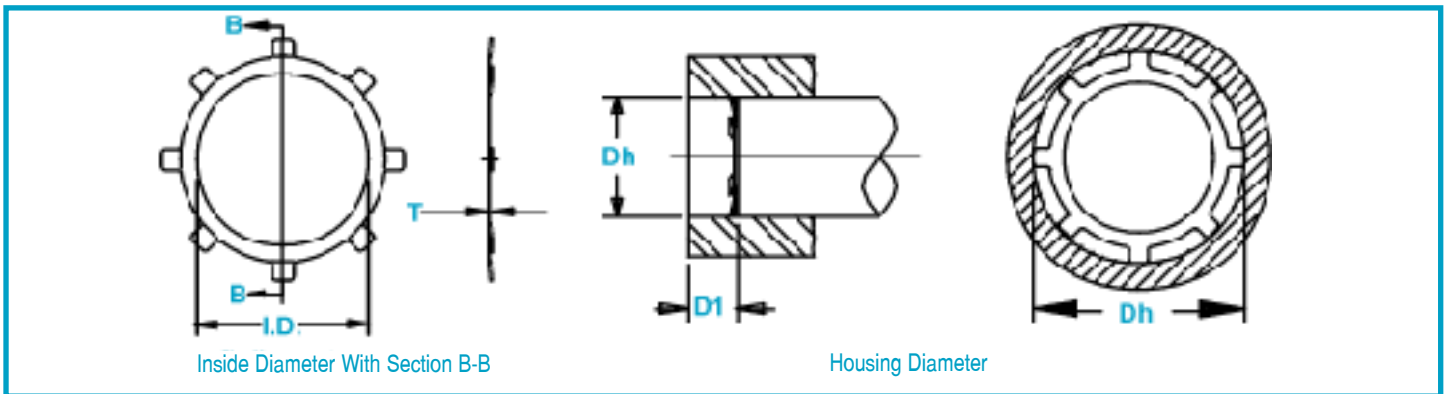

TI Rings

Internal, Self-Locking

Prongs dig into the housing when load is introduced to other side.



RING NO.	HOUSING DIAMETER Inches				RING SIZE & WEIGHT								Min. Distance Face of part to end of housing		
					INSIDE DIAMETER		THICKNESS***		No. of Prongs	Thrust Load	Weight Per 1000 Pcs.	D1			
	FROM	TO	FRACT	mm	I.D.	Tol.	T	Tol.						lbs.	lbs.
TI-31	.311	.313	5/16	7.92	.136	±.005	.010	±.001	6	81	.11	.040			
TI-37	.374	.376	3/8	9.53	.175				6	76	.16	.040			
TI-43	.437	.439	7/16	11.13	.237				6	71	.20	.040			
TI-44	.440	.442	-	11.20	.258				6	41	.18	.040			
TI-50	.498	.502	1/2	12.7	.258				6	61	.24	.040			
TI-56	.560	.564	9/16	14.27	.312				6	51	.29	.040			
TI-62	.623	.627	5/8	15.85	.390				6	46	.30	.040			
TI-63	.638	.640	-	16.23	.390				6	43	.32	.040			
TI-75	.748	.752	3/4	19.05	.500				±.010	.015	±.002	8	76	.62	.060
TI-87	.873	.877	7/8	22.23	.625							8	71	.75	.060
TI-93	.936	.940	15/16	23.83	.687	10	71	.85				.060			
TI-100	.998	1.002	1	25.4	.750	10	75	.91				.060			
TI-112	1.123	1.127	1 1/8	28.58	.813	10	60	1.30				.060			
TI-125	1.248	1.252	1 1/4	31.75	.938	10	60	1.50				.060			
TI-143	1.436	1.44	1 7/16	36.51	1.117	12	60	1.73				.060			
TI-150	1.498	1.502	1 1/2	38.10	1.188	12	60	1.80				.060			
TI-175	1.748	1.752	1 3/4	44.45	1.438	12	55	2.10				.060			
TI-200	1.998	2.002	2	50.80	1.600	14	55	3.00				.060			

*** FOR PLATED RINGS ADD .002" TO MAXIMUM THICKNESS.

LARGER SIZES MAY BE AVAILABLE UPON REQUEST.

† BASED ON HOUSINGS/SHAFTS MADE OF COLD ROLLED STEEL. FOR AN EXPLANATION OF FORMULAS USED TO DERIVE THRUST LOAD AND OTHER PERFORMANCE DATA, CONTACT THE ROTOR CLIP ENGINEERING DEPT. THRUST LOAD CAPACITY IF APPLICABLE TO PARTS MADE FROM CARBON SPRING STEEL AND STAINLESS STEEL MATERIALS ONLY.

HARDNESS RANGES: STAINLESS STEEL RINGS (PH 15-7MO)

RING TYPE	SIZE RANGE	SCALE	ROCKWELL HARDNESS
TI	31-62	15N	82.5-86*
	75+	15N	82.5-86

*HARDNESS CAN NOT BE CHECKED WITH ANY DEGREE OF ACCURACY DIRECTLY ON THESE RINGS.

HARDNESS RANGES: BERYLLIUM COPPER RINGS

RING TYPE	SIZE RANGE	SCALE	ROCKWELL HARDNESS
TI	31-62	15N	77-82*
	75+	15N	77-82

*HARDNESS CAN NOT BE CHECKED WITH ANY DEGREE OF ACCURACY DIRECTLY ON THESE RINGS.

HARDNESS RANGES: CARBON STEEL RINGS (SAE 1060-1090)

RING TYPE	SIZE RANGE	SCALE	ROCKWELL HARDNESS
TI	31-62	15N	84-86*
	75+	15N	84-86

*HARDNESS CAN NOT BE CHECKED WITH ANY DEGREE OF ACCURACY DIRECTLY ON THESE RINGS.

PLUNGER

For Fast, Easy Installation Of Rotor Clip TX, TY Rings.

See page 162 for the "Easy Guide" TX Applicator Tool.

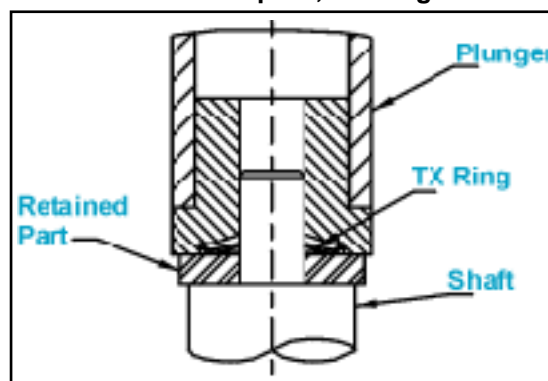

A cylindrical plunger can be easily made to install TX, TY rings. The ring is positioned at the opening of the plunger and then pushed or tapped onto the shaft, as illustrated.