

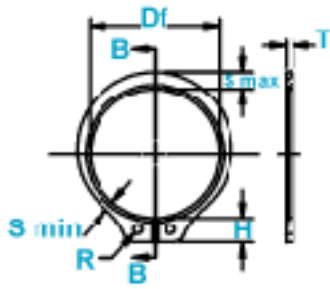

VSH Shaft Rings

Axially Assembled, External

A 15° beveled edge along with a complimentary groove angle combine to eliminate end play when the ring is installed.



Free Diameter & Ring Measurements with Section B-B

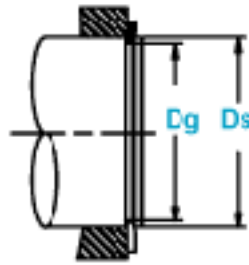

Shaft Diameter & Groove Dimensions



Clearance Diameter Expanded Over Shaft



Clearance Diameter & Gaging Diameter Released in Groove

RING NO.	SHAFT DIAMETER D			GROOVE SIZE				RING SIZE & WEIGHT						CLEARANCE DIA.	
	Ds DEC	Ds FRACT	Ds mm	Dg	DIAMETER		EPTH	FREE DIAMETER		THICKNESS**		THICKNESS BEVELED END	WEIGHT PER 1000 PCS.	EX-PANDED OVER SHAFT	RE-LEASED IN GROOVE
					Tol.	W		Tol.	d	Df	Tol.				
VSH-100	1.000	1	25.4	.930	+.000	.037	.035	.925	+.005	.042	.034	3.6	1.41	1.38	
VSH-102	1.023	-	26.0	.951	-.003 .004*	.036	.036	.946	-.010	.042	.033	3.9	1.43	1.40	
VSH-106	1.062	1-1/16	27.0	.992		.044	.035	.982		.050	.041	4.8	1.50	1.47	
VSH-112	1.125	1-1/8	28.6	1.051		.044	.037	1.041		.050	.041	5.1	1.55	1.52	
VSH-119	1.188	1-3/16	30.2	1.108	+.000	.044	.040	1.098	+.010	.050	±.002	5.6	1.61	1.57	
VSH-125	1.250	1-1/4	31.7	1.166	-.004	.043	.042	1.156	-.015	.050	.040	5.9	1.69	1.65	
VSH-131	1.312	1-5/16	33.3	1.224	.005*	.042	.044	1.214		.050	.039	6.8	1.75	1.71	
VSH-137	1.375	1-3/8	34.9	1.282		.042	.046	1.272		.050	.039	7.2	1.80	1.76	
VSH-143	1.438	1-7/16	36.5	1.343		.041	.047	1.333		.050	.039	8.1	1.87	1.83	
VSH-150	1.500	1-1/2	38.1	1.397		.053	.051	1.387		.050	.038	9.0	1.99	1.95	
VSH-157	1.562	1-9/16	39.7	1.459		.053	.051	1.446		.062	.049	12.4	2.10	2.05	
VSH-162	1.625	1-5/8	41.3	1.516		.053	.054	1.503		.062	.049	13.2	2.17	2.13	
VSH-168	1.688	1-11/16	42.9	1.573	+.000	.052	.057	1.560	+.013	.062	±.003	14.8	2.24	2.20	
VSH-175	1.750	1-3/4	44.4	1.631	-.005	.052	.059	1.618	-.020	.062	.048	15.3	2.31	2.26	
VSH-177	1.772	-	45.0	1.650	.005*	.052	.061	1.637		.062	.048	15.4	2.33	2.28	
VSH-181	1.812	1-13/16	46.0	1.688		.052	.062	1.675		.062	.048	16.2	2.38	2.33	
VSH-187	1.875	1-7/8	47.6	1.748		.051	.063	1.735		.062	.048	17.3	2.44	2.39	
VSH-196	1.969	1-31/32	50.0	1.832		.067	.068	1.819		.062	.047	18.0	2.54	3.09	
VSH-200	2.000	2	50.8	1.863		.067	.068	1.850		.062	.047	19.0	2.57	3.10	
VSH-206	2.062	2-1/16	52.4	1.921		.067	.070	1.906		.078	.062	25.0	2.68	3.22	
VSH-212	2.125	2-1/8	54.0	1.979	+.000	.067	.073	1.964	+.015	.078	±.0015	26.1	2.78	3.29	
VSH-215	2.156	2-5/32	54.8	2.008	-.006	.067	.074	1.993	-.025	.078	.062	26.3	2.81	3.40	
VSH-225	2.250	2-1/4	57.1	2.096	.006*	.065	.077	2.081		.078	.061	27.7	2.90	3.51	
VSH-231	2.312	2-5/16	58.7	2.154		.065	.079	2.139		.078	.060	28.0	2.97	3.58	
VSH-237	2.375	2-3/8	60.3	2.212		.065	.081	2.197		.078	.060	29.2	3.06	3.50	
VSH-243	2.438	2-7/16	61.9	2.270		.065	.084	2.255		.078	.060	29.5	3.07	3.64	
VSH-250	2.500	2-1/2	63.5	2.328		.064	.086	2.313		.078	.059	29.7	3.17	3.09	
VSH-255	2.559	-	65.0	2.397		.064	.081	2.377	+.020	.078	.059	33.9	3.18	3.10	
VSH-262	2.625	2-5/8	66.7	2.448		.064	.088	2.428	-.030	.078	.059	35.0	3.30	3.22	
VSH-268	2.688	2-11/16	68.3	2.505		.064	.091	2.485		.078	.059	36.0	3.37	3.29	
VSH-275	2.750	2-3/4	69.8	2.563		.079	.093	2.543		.093	.073	47.0	3.48	3.40	
VSH-287	2.875	2-7/8	73.0	2.679		.078	.098	2.659		.093	.072	48.5	3.60	3.51	
VSH-293	2.938	2-15/16	74.6	2.737		.078	.100	2.717		.093	.072	50.0	3.67	3.58	
VSH-300	3.000	3	76.2	2.795		.077	.102	2.775		.093	.071	52.0	3.60	3.50	
VSH-306	3.062	3-1/16	77.8	2.852		.077	.105	2.832		.093	.071	47.0	3.74	3.64	

*** FOR PLATED RINGS, ADD .002" TO THE LISTED MAXIMUM THICKNESS (T) AND BEVELED END THICKNESS (U) VALUES.
 * F.I.M. (FULL INDICATOR MOVEMENT)-MAXIMUM ALLOWABLE DEVIATION OF CONCENTRICITY BETWEEN GROOVE AND SHAFT.
 FOR HARDNESS SPECIFICATIONS, SEE END OF THIS SECTION.

NOTE: THESE HARDNESS CHARTS ARE FOR THE VHO RINGS SHOWN ON THE PREVIOUS 4 PAGES.

HARDNESS RANGES: STAINLESS STEEL RINGS (PH 15-7MO)

RING TYPE	SIZE RANGE	SCALE	ROCKWELL HARDNESS
VHO	100&102	30N	63-69.5
	106+	C	44-51

NOTE: THESE HARDNESS CHARTS ARE FOR THE VHO RINGS SHOWN ON THE PREVIOUS 4 PAGES.

HARDNESS RANGES: BERYLLIUM COPPER RINGS

RING TYPE	SIZE RANGE	SCALE	ROCKWELL HARDNESS
VHO	100&102	30N	54-62
	106+	C	34-43

For technical assistance call **1-800-55-ROTOR**

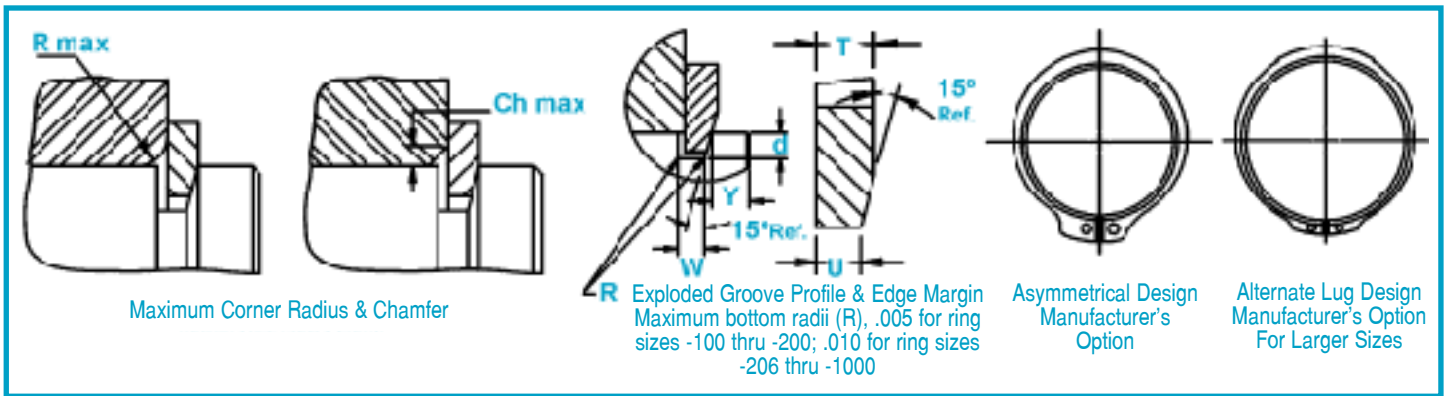

RING NO.	ALLOWABLE CORNER RADII & CHAMFERS		MAX L OAD W/ R MAX OR CH MAX (IN LBS.)	EDGE MARGIN	END PLAY TAKE-UP		LUG HEIGHT	MAXIMUM SECTION R		MINIMUM SECTION		HOLEG DIAMETER		AG-NG DIA.	THRUST LOAD (lbs.) SQR. CORNER ABUTMENT	
	R max	Ch max			P'r	Y		In.	H	Tol.	S max	Tol.	S min		Tol.	R
VSH-100	.057	.034	1340	.052	.005	.167		.116	±.005	.065	±.005	.078		1.144	5024	1200
VSH-102	.058	.035	1340	.054	.005	.168		.118		.066		.078		1.170	5126	1300
VSH-106	.060	.036	1950	.052	.005	.181		.122		.069		.078		1.217	6293	1300
VSH-112	.063	.038	1950	.055	.005	.182		.128		.071		.078		1.286	6699	1450
VSH-119	.064	.0385	1950	.060	.005	.198		.132		.072		.078		1.351	7105	1650
VSH-125	.068	.041	1950	.063	.0055	.183		.140		.076		.078		1.424	7460	1850
VSH-131	.068	.041	1950	.066	.006	.183		.146		.0765		.078		1.490	7866	2000
VSH-137	.072	.043	1950	.069	.006	.184		.152		.082		.078		1.562	8222	2250
VSH-143	.076	.045	1950	.070	.006	.184	±.004	.160	±.006	.086	±.006	.078	+ .015 - .002	1.636	8628	2450
VSH-150	.079	.047	1950	.076	.007	.214		.168		.091		.078		1.706	8932	2700
VSH-157	.082	.049	3000	.076	.007	.255		.172		.093		.125		1.778	11571	2900
VSH-162	.087	.052	3000	.081	.0075	.235		.180		.097		.125		1.849	12028	3100
VSH-168	.090	.054	3000	.085	.0075	.235		.184		.099		.125		1.912	12535	3400
VSH-175	.091	.054	3000	.088	.008	.237		.188		.101		.125		1.981	12992	3650
VSH-177	.092	.055	3000	.090	.008	.237		.190		.102		.125		2.004	13144	3750
VSH-181	.092	.055	3000	.093	.008	.238		.192		.102		.125		2.047	13449	3950
VSH-187	.094	.056	3000	.094	.0085	.239		.196		.104		.125		2.114	13906	4200
VSH-196	.094	.056	3000	.102	.009	.245		.200		.106		.125		2.209	14565	4700
VSH-200	.096	.057	3000	.102	.009	.239		.204		.108		.125		2.246	14819	4800
VSH-206	.098	.059	5000	.105	.0095	.266		.208		.111		.125		2.315	19234	5100
VSH-212	.098	.059	5000	.109	.010	.280		.212		.113		.125		2.386	19793	5450
VSH-215	.097	.058	5000	.111	.010	.280		.212		.113		.125		2.410	20097	5600
VSH-225	.100	.060	5000	.115	.010	.280		.220		.116		.125		2.513	21011	6100
VSH-231	.100	.060	5000	.118	.0105	.280		.222		.118		.125		2.577	21518	6300
VSH-237	.100	.060	5000	.121	.011	.292		.224		.119		.125		2.640	22127	6800
VSH-243	.102	.061	5000	.126	.011	.268		.228		.120		.125		2.706	22736	7100
VSH-250	.104	.062	5000	.129	.0115	.292	±.005	.232	±.007	.122	±.007	.125		2.772	23345	7500
VSH-255	.108	.065	5000	.121	.011	.268		.238		.125		.125		2.845	23853	7300
VSH-262	.1095	.066	5000	.132	.0115	.292		.242		.127		.125		2.910	24462	8200
VSH-268	.1115	.067	5000	.136	.012	.292		.246		.129		.125		2.975	25071	8600
VSH-275	.112	.067	7350	.139	.012	.324		.248		.131		.125		3.041	30552	9000
VSH-287	.115	.069	7350	.147	.013	.324		.256		.133		.125		3.172	31973	9900
VSH-293	.116	.070	7350	.150	.0135	.324		.260		.136		.125		3.239	32683	10300
VSH-300	.117	.070	7350	.153	.0135	.264		.264		.138		.125		3.306	33394	10700
VSH-306	.107	.064	7350	.157	.014	.300		.300		.131		.125		3.347	34003	11200

† BASED ON HOUSINGS/SHAFTS MADE OF COLD ROLLED STEEL. FOR AN EXPLANATION OF FORMULAS USED TO DERIVE THRUST LOAD AND OTHER PERFORMANCE DATA, CONTACT THE ROTOR CLIP ENGINEERING DEPARTMENT. FOR HARDNESS SPECIFICATIONS, SEE END OF THIS SECTION.

NOTE: THESE HARDNESS CHARTS ARE FOR THE VHO RINGS SHOWN ON THE PREVIOUS 4 PAGES.

HARDNESS RANGES: CARBON STEEL RINGS (SAE 1060-1090)

RING TYPE	SIZE RANGE	SCALE	ROCKWELL HARDNESS
VHO	100&102	30N	66-71
	106-347	C	47-52
	350-700	C	44-51
	725-1000	C	40-47



VSH Shaft Rings

Axially Assembled, External

A 15° beveled edge along with a complementary groove angle combine to eliminate end play when the ring is installed.

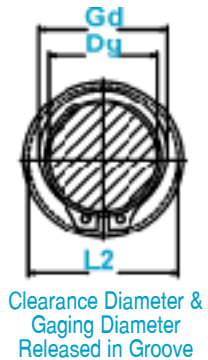
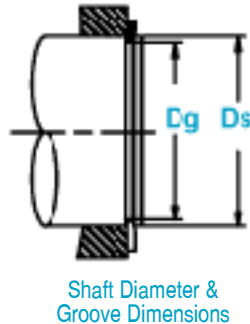
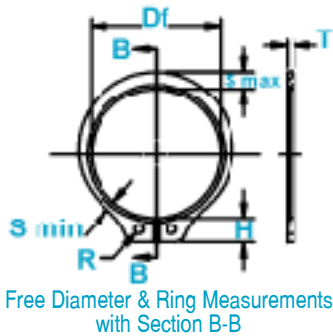

RING NO.	SHAFT			GROOVE SIZE			RING SIZE & WEIGHT						CLEARANCE DIA.				
	DIAMETER			DIAMETER		WIDTH	DEPTH	FREE DIAMETER			THICKNESS***		THICKNESS BEVELED END	WEIGHT PER 1000 PCS.	EX-PANDED OVER SHAFT	RE-LEASED IN GROOVE	
	Ds DEC	Ds FRACT	Ds mm	Dg	Tol.	W	Tol.	d	Df	Tol.	T	Tol.	U	Tol.	lbs.	L1	L2
VSH-312	3.125	3-1/8	79.4	2.912		.076		.106	2.892		.093		.070		58.0	3.85	3.76
VSH-315	3.156	3-5/32	80.2	2.940	+.000	.076	+.007	.108	2.920		.093		.070		59.0	3.88	3.78
VSH-325	3.250	3-1/4	82.5	3.026	-.006	.076	-.000	.112	3.006		.093		.070	±.002	62.0	3.93	3.83
VSH-334	3.346	3-11/32	85.0	3.112	.006*	.075		.117	3.092	+.020	.093		.069		64.0	4.02	3.92
VSH-343	3.438	3-7/16	87.3	3.199		.075		.119	3.179	-.030	.093		.069		66.0	4.12	4.01
VSH-350	3.500	3-1/2	88.9	3.257		.091		.121	3.237		.109		.084		72.0	4.16	4.05
VSH-354	3.543	-	90.0	3.297		.091		.123	3.277		.109		.084		73.0	4.25	4.14
VSH-362	3.625	3-5/8	92.1	3.372		.090		.126	3.352		.109		.083		76.0	4.33	4.21
VSH-368	3.688	3-11/16	93.7	3.430		.090		.129	3.410		.109	±.003	.083		80.0	4.39	4.27
VSH-375	3.750	3-3/4	95.2	3.488		.089		.131	3.468		.109		.082		83.0	4.52	4.40
VSH-387	3.875	3-7/8	98.4	3.604		.089		.135	3.584		.109		.082		88.0	4.62	4.49
VSH-393	3.938	3-15/16	100.0	3.662		.088	+.008	.138	3.642		.109		.081	±.0025	95.0	4.70	4.57
VSH-400	4.000	4	101.6	3.720		.088	-.000	.140	3.700		.109		.081		101.0	4.76	4.63
VSH-425	4.250	4-1/4	108.0	4.009		.094		.120	3.989		.109		.087		112.0	4.98	4.87
VSH-437	4.375	4-3/8	111.1	4.126		.094		.124	4.106		.109		.087		115.0	5.11	4.99
VSH-450	4.500	4-1/2	114.3	4.243		.094		.128	4.223		.109		.087		132.0	5.37	5.25
VSH-475	4.750	4-3/4	120.6	4.478		.092		.136	4.458		.109		.085		113.0	5.62	5.49
VSH-500	5.000	5	127.0	4.712		.091		.144	4.692		.109		.084		149.0	5.87	5.74
VSH-525	5.250	5-1/4	133.3	4.947	+.000	.105		.151	4.927		.125		.098		190.0	6.20	6.05
VSH-550	5.500	5-1/2	139.7	5.182	-.007	.104		.159	5.162	+.020	.125	±.004	.097		201.0	6.45	6.30
VSH-575	5.750	5-3/4	146.0	5.416	.006*	.103		.167	5.396	-.040	.125		.096		199.0	6.69	6.53
VSH-600	6.000	6	152.4	5.651		.102		.174	5.631		.125		.095		210.0	6.95	6.78
VSH-625	6.250	6-1/4	158.7	5.886		.132		.182	5.866		.156		.124		282.0	7.31	7.14
VSH-650	6.500	6-1/2	165.1	6.120		.131		.190	6.100	+.020	.156		.123		330.0	7.67	7.49
VSH-675	6.750	6-3/4	171.4	6.355		.130		.197	6.335	-.050	.156		.122	±.003	356.0	8.06	7.87
VSH-700	7.000	7	177.8	6.590		.129		.205	6.570		.156		.121		388.0	8.13	7.93
VSH-750	7.500	7-1/2	190.5	7.059		.158		.220	7.039		.187		.149		534.0	8.70	8.49
VSH-800	8.000	8	203.2	7.528	+.000	.157		.236	7.508		.187	±.005	.148		628.0	9.24	9.01
VSH-850	8.500	8-1/2	215.9	7.997	-.008	.154		.251	7.977	+.020	.187		.145		700.0	9.79	9.54
VSH-900	9.000	9	228.6	8.465	.006*	.153		.267	8.445	-.060	.187		.144		757.0	10.60	10.34
VSH-950	9.500	9-1/2	241.3	8.935		.150		.282	8.915		.187		.141		820.0	11.10	10.82
VSH-1000	10.000	10	254.0	9.405		.148		.297	9.385		.187		.139		964.0	11.61	11.32

* F.I.M. (FULL INDICATOR MOVEMENT)-MAXIMUM ALLOWABLE DEVIATION OF CONCENTRICITY BETWEEN GROOVE AND SHAFT.

***FOR PLATED RINGS ADD .002" TO THE LISTED MAXIMUM THICKNESS. MAXIMUM RING THICKNESS WILL BE A MINIMUM OF .0002" LESS THAN THE LISTED GROOVE WIDTH (W) MINIMUM.

For technical assistance call 1-800-55-ROTOR

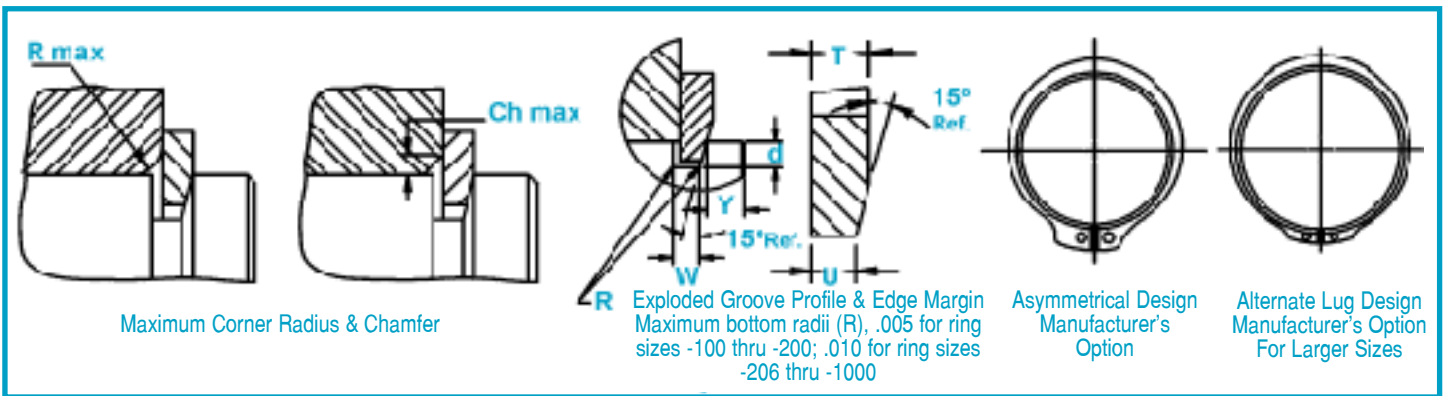

RING NO.	ALLOWABLE CORNER RADII & CHAMFERS		MAX. LOAD W/ R MAX OR CH MAX (IN LBS.)	EDGE MARGIN Y	END-PLAY TAKE-UP In.	LUG HEIGHT H		MAXIMUM SECTION S max		MINIMUM SECTION S min		HOLE DIAMETER R		GAG-GING DIA. Gd Max	THRUST LD. (LBS.) SQR. CORNER ABUTMENT	
	R max	Ch max				(lbs.)	H	Tol.	S max	Tol.	S min	Tol.	R		Tol.	Pr
VSH-312	.120	.072	7350	.159	.014	.324		.272		.141		.125		3.439	34815	11700
VSH-315	.1205	.072	7350	.162	.0145	.324		.274		.143		.125		3.469	35119	11900
VSH-325	.123	.074	7350	.168	.015	.300		.300		.145		.125		3.571	36134	12700
VSH-334	.126	.076	7350	.175	.0155	.300		.300		.147		.125		3.669	37251	13600
VSH-343	.129	.077	7350	.178	.016	.300	±.005	.300	±.008	.148	±.008	.125	+ .015	3.767	38266	14300
VSH-350	.122	.073	10500	.181	.016	.285		.285		.148		.125	-.002	3.821	45574	14800
VSH-354	.123	.074	10500	.184	.0165	.310		.310		.149		.125		3.866	46183	15200
VSH-362	.127	.076	10500	.189	.017	.310		.310		.153		.125		3.956	47299	16300
VSH-368	.1295	.078	10500	.193	.017	.310		.310		.156		.125		4.026	48010	16500
VSH-375	.133	.080	10500	.196	.0175	.342		.342		.160		.125		4.098	48822	17200
VSH-387	.137	.082	10500	.202	.018	.342		.342		.163		.125		4.229	50446	18300
VSH-393	.137	.082	10500	.207	.0185	.342		.342		.163		.125		4.290	51359	19000
VSH-400	.135	.081	10500	.210	.019	.342		.342		.163		.125		4.350	52171	19600
VSH-425	.146	.088	10500	.180	.016	.342		.342		.176		.125		4.620	55419	18000
VSH-437	.146	.088	10500	.186	.017	.342		.342		.181		.125		4.740	57043	19000
VSH-450	.102	.061	10500	.192	.017	.405		.405		.185		.125		4.920	58667	20200
VSH-475	.115	.069	10500	.204	.018	.405		.405		.136		.125		5.060	61915	22700
VSH-500	.165	.099	10500	.216	.019	.405	±.008	.405	±.010	.194	±.010	.156		5.410	65163	25400
VSH-525	.169	.101	13500	.226	.020	.435		.435		.211		.156		5.670	78460	28000
VSH-550	.175	.105	13500	.238	.021	.435		.390		.209		.156		5.940	82215	30800
VSH-575	.184	.110	13500	.250	.022	.435		.435		.220		.156		6.210	85971	33800
VSH-600	.143	.086	13500	.261	.023	.435		.435		.171		.156		6.380	89625	37000
VSH-625	.148	.089	21000	.273	.024	.485		.485		.176		.156	+ .020	6.650	116522	40000
VSH-650	.191	.114	21000	.285	.025	.485		.485		.236		.156	-.005	6.980	121191	43500
VSH-675	.200	.120	21000	.295	.026	.515		.515		.246		.187		7.260	125860	47000
VSH-700	.208	.125	21000	.307	.027	.515		.515		.256		.187		7.520	130529	50500
VSH-750	.220	.132	30000	.330	.029	.545	±.012	.545	±.015	.277	±.015	.187		8.060	167678	58000
VSH-800	.235	.141	30000	.354	.032	.560		.560		.294		.187		8.590	178843	66500
VSH-850	.250	.150	30000	.376	.034	.580		.580		.314		.187		9.130	190008	75000
VSH-900	.267	.160	30000	.400	.036	.735		.609		.333		.187		9.670	201173	86000
VSH-950	.281	.168	30000	.423	.038	.735		.642		.350		.187		10.200	212338	94500
VSH-1000	.294	.176	30000	.445	.040	.735		.675		.367		.187		10.730	223503	105000

† BASED ON HOUSINGS/SHAFTS MADE OF COLD ROLLED STEEL. FOR AN EXPLANATION OF FORMULAS USED TO DERIVE THRUST LOAD AND OTHER PERFORMANCE DATA, CONTACT THE ROTOR CLIP ENGINEERING DEPARTMENT.

HARDNESS RANGES: STAINLESS STEEL RINGS (PH 15-7MO)

RING TYPE	SIZE RANGE	SCALE	ROCKWELL HARDNESS
VSH	All	C	44-51

HARDNESS RANGES: BERYLLIUM COPPER RINGS

RING TYPE	SIZE RANGE	SCALE	ROCKWELL HARDNESS
VSH	100-102	30N	56.5-62
	106+	C	37-43

HARDNESS RANGES: CARBON STEEL RINGS (SAE 1060-1090)

RING TYPE	SIZE RANGE	SCALE	ROCKWELL HARDNESS
VSH	100-102	C	47-53
	106-343	C	47-52
	350-700	C	44-51
	725-1000	C	40-47