

Turcon® Rotary Shaft Seals

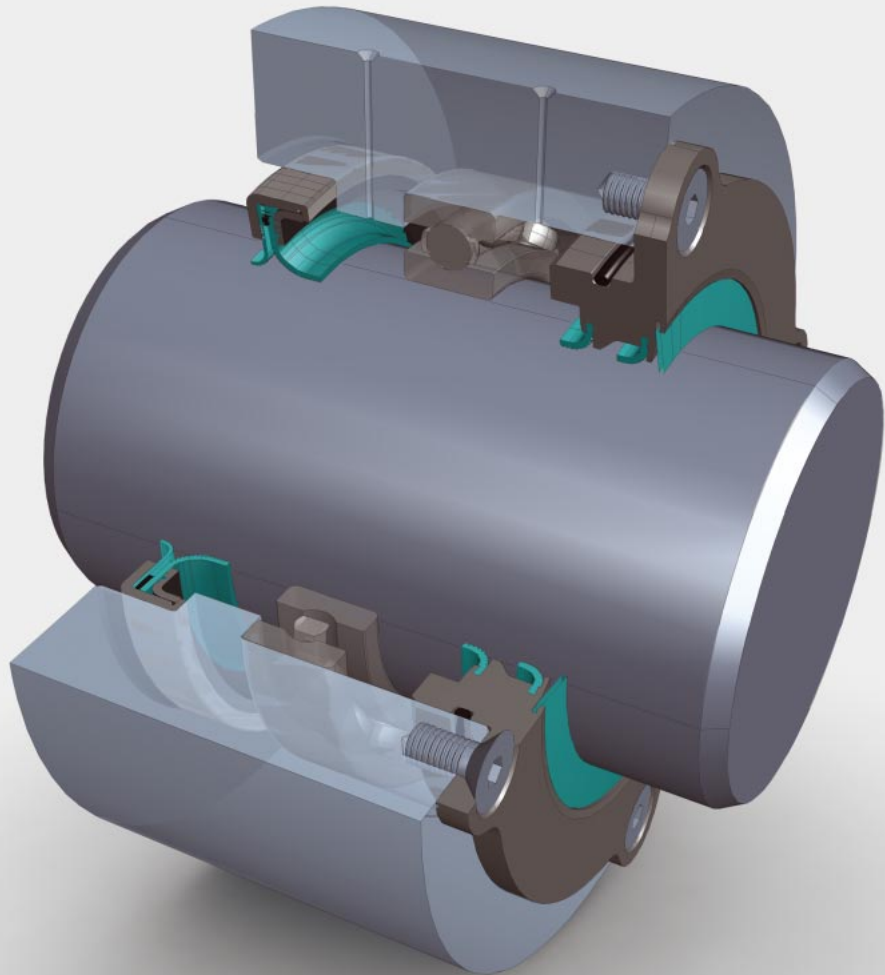

Varilip® and Varilip® PDR



Your Partner for Sealing Technology

Busak+Shamban



Turcon® Rotary Shaft Seals

Busak+Shamban forms part of Trelleborg Sealing Solutions, a business area within Trelleborg AB and is a major manufacturer and supplier of PTFE seals and engineered components to industries throughout the world.

Manufacturing resources comprise 36 technology led centres dedicated to the production of sealing and bearing products.

Complementing these fully integrated production facilities, Busak+Shamban customer service is built on real values - an in depth understanding of customer expectations, an ability to quickly respond, an interactive approach to providing effective and appropriate solutions and logistics support from over 30 marketing centres across the globe.

Continuous improvement environments present in all facilities reflect approvals to a wide range of industry and quality standards, including ISO9001-2000, FAA/CAA, AS9000, QS9000 and ISO14000.



The PTFE Rotary Seals product range is manufactured by Trelleborg Wills Polymers and the origins of this product were established in 1981 for the design and manufacture of specialised seals in a wide range of application fields. In addition, a standard product range has been available since 1991.

Our products serve core market sectors such as Industrial, Aerospace and Automotive in addition to specialised niche markets.

We supply seals in quantities ranging from development parts and small production batches through to many hundreds of thousands per year.

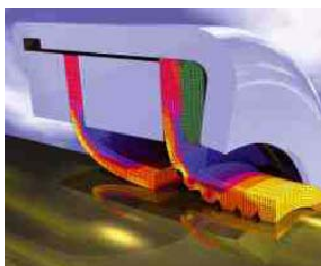

A major feature of our service is design flexibility.

Whilst we are more than capable of producing straightforward seals for fitting in applications that may have already been designed around conventional elastomeric seals, many of our customers contact us at an early stage to design bespoke seals for applications specific to their sealing needs.

This allows the opportunity to suggest weight and size reduction, the possible inclusion of the seal into other components and to put forward cost savings.

These important benefits can be obtained by contacting our designers before seal housing dimensions are finalised.



We routinely use advanced non-linear finite element analysis on all new designs and employ 3D design techniques where advantageous.

Comprehensive material testing facilities enable the creation of in house FEA material models to accurately determine shaft loadings and provide data for design calculations.

Extensive rotary testing facilities are used for material development, product development and customer testing.

Purpose built test rigs include special features such as air bearings and sophisticated torque measuring electronics for the development of low friction PTFE seals at speeds up to 20,000 rpm, well in excess of more typical rotary seal test equipment.

Environmental cabinets enable all of the above rotary testing to be carried out in the most extreme of environmental conditions.

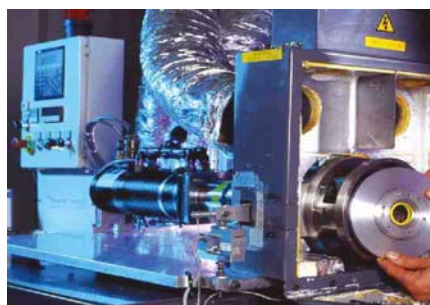



Contents

Description	2
Product Range	3
Materials	5
Operating Parameters	7
Design Guidelines	10
Packaging	13
Fitting Instructions	13
Installation Recommendations	15
Selection Guide	16
Varilip® Standard Sizes	17
Technical & Purchasing Questionnaire	23

The information in this brochure is based on many decades of experience in the manufacture and application of sealing and bearing systems. However, unknown parameters and conditions may restrict general statements during usage. It is vital that Customers satisfy themselves as to the suitability of individual products through adequate testing. For this reason, and due to the wide range of applications of our products, Busak+Shamban can accept no liability as to the suitability or correctness of our recommendations in individual cases. The application limits for pressure, temperature, speed and media given in this brochure are maximum values determined in the laboratory. During practical applications it should be remembered that due to the interaction of the operating parameters, the maximum values must be set correspondingly lower.

For exceptional operating conditions, please contact your Busak+Shamban representative.

This edition supersedes all previous brochures. This brochure, or any part thereof, may not be reproduced without our permission.

® All trademarks are the property of Busak+Shamban.

© Busak+Shamban 2004. All rights reserved.

The turquoise colour is a registered trademark of Busak+Shamban.



■ Description

Turcon® rotary shaft seals extend the boundaries imposed by elastomer radial shaft seals, utilising advanced materials and design techniques to provide optimum sealing performance for each application. The outcome is a superior sealing solution which retains a compact seal envelope.

Standard elastomeric rotary shaft seals have a limited application range with respect to temperature, surface speed, media compatibility, pressure or a combination of these due to the inherent limitations of the various elastomer grades.

Furthermore they only have a limited suitability for applications with inadequate lubrication.

Turcon® rotary shaft seals are characterised in particular by the low friction and their stick-slip-free running, thus reducing the heat development and permitting higher peripheral speeds.

Turcon® has the characteristic of inherent memory, whereby a distorted Turcon® component will attempt to recover to the profile it had during the sintering cycle of its manufacturing process. This feature is used to provide the necessary radial loading of the sealing lip onto the shaft, therefore negating the requirement for the energising spring present in elastomeric seal designs.

Where required, seals can employ hydrodynamic sealing, which, in conjunction with mechanical retention of the Turcon® in the seal body, gives exceptional seal performance.





■ Product Range

Turcon® rotary shaft seals from Busak+Shamban are available in two product ranges: Varilip® and Varilip® PDR. These ranges are designed to encompass standard solutions to a wide range of applications and also bespoke seal designs for applications where a standard product may not achieve desired levels of performance.

Varilip®

6 different types of Varilip® seal are available in a range of sizes suitable for DIN/ISO standard housing and groove sizes. Varilip® seals use a plain lip and can thus be used on shafts that rotate in either direction.

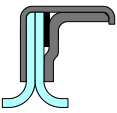
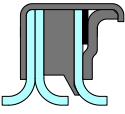
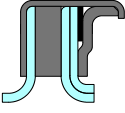
Seal	Description
Type A 	Type A - is a single lip seal suitable for use in standard industrial applications up to a pressure of 0.5 MPa where an elastomer radial shaft seal would be unable to withstand the temperature, friction, medium or poor lubrication. Allows sealing at surface speeds up to 30m/s with sufficient cooling and lubrication of the sealing lip.
Type B 	Type B - is the preferred choice for applications in which a high seal integrity is demanded or where contaminated media are to be sealed. This type offers a "back-up" sealing lip to provide greater safety than the Type A.
Type C 	Type C - can be used for applications involving higher pressures for which a simple elastomer radial shaft seal can no longer be considered. Due to reinforcement of the sealing lip, pressures up to 2 MPa are possible, e.g. as pump, shaft or rotor seals.
Type D 	Type D - can be subjected to pressure from both sides. Pressure differential of up to 0.1 MPa is permissible. The separation of two different media using a single seal is possible. The second lip can also take on the function of a wiper or dust lip.
Type E 	Types E is similar to Type B but has an additional lip to prevent contaminants from reaching the sealing lips. This enables an effective solution in environments where the seal may be exposed to abrasive particles.
Type F 	Types F is similar to type C but has an additional lip to prevent contaminants from reaching the sealing lips. This enables an effective solution in environments where the seal may be exposed to abrasive particles.



Turcon® Rotary Shaft Seals

Varilip® PDR

These seals are individually designed to satisfy the demands of specific applications and can therefore accommodate non-standard housing and shaft sizes. Typically they consist of a pressed or machined casing and a mechanically retained Turcon® element and in many applications they do not require the use of a gasket, thus improving the chemical resistance of the seal system. Where required, Varilip® PDR seals can employ a hydrodynamic feature on the Turcon® sealing lip. This provides a positive displacement of the fluid as a result of the shaft rotation to give improved sealing in applications where the shaft only rotates in a single direction. The feature also increases the flexibility of the lip which allows a wider contact band between the Turcon® lip and the shaft and helps to reduce shaft load and associated wear.

Varilip® PDR seals are produced as one of 3 basic design styles, termed 'clamped', 'crimped' and 'single shell', as illustrated in figures NO TAG, NO TAG and NO TAG. Axially split housings or housings with a poor surface finish or enlarged tolerance can be accommodated with the use of a rubber OD cover or O-Ring.

Varilip® PDR's relatively simple design and the nature of the machined or pressed casings promote the potential for integration of the seal into the surrounding hardware. Furthermore, the mechanical retention of the Turcon® provides a robust product which also eliminates the sometimes environmentally hazardous process of bonding the Turcon® to a metal or elastomer substrate.

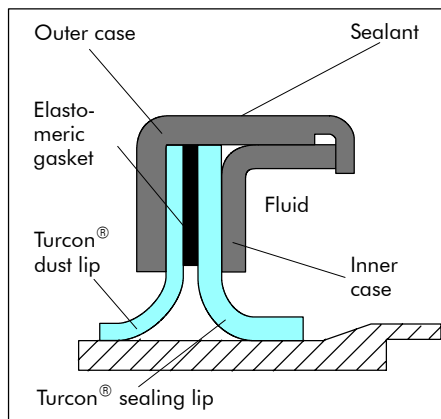

Figure 1 Clamped design

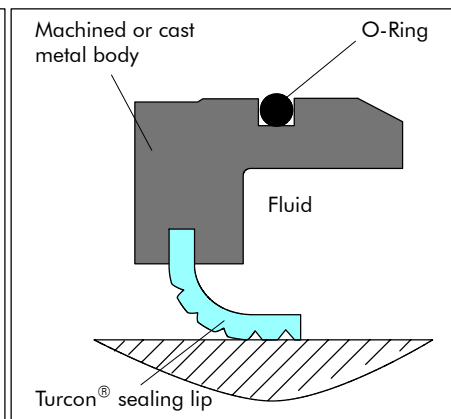

Figure 2 Crimped design

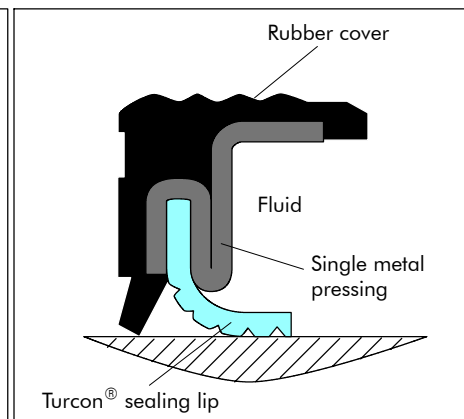

Figure 3 Single shell design

A selection of typical seal designs available using Varilip® PDR technology is shown in Figure 4.

Variants of these designs can be produced for applications where it is beneficial to have the dynamic sealing surface at the housing, rather than the shaft.

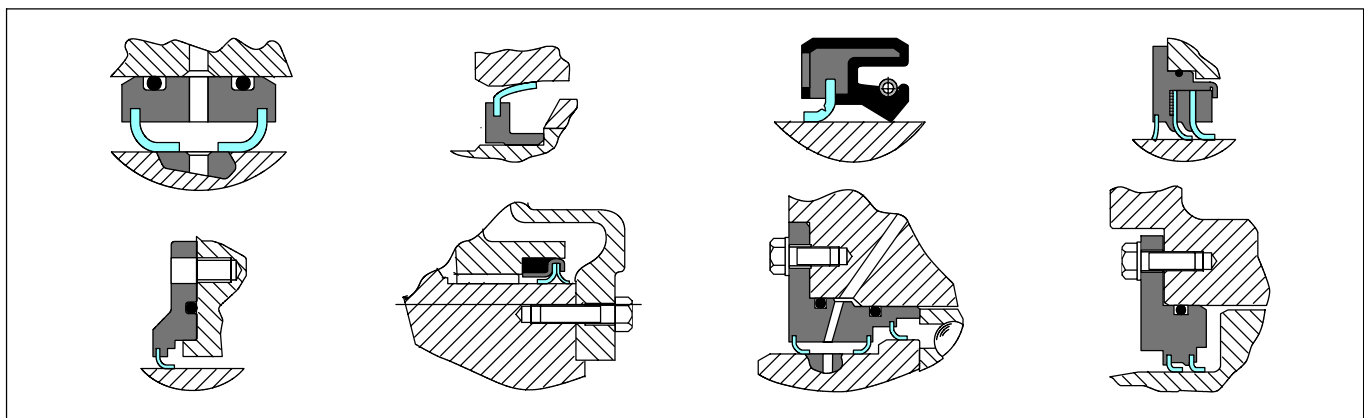

Figure 4 Variants



Materials

Sealing lip

An important factor for the proper function of rotational seals is the material used for the sealing lip. For this reason, Busak+Shamban has developed a range of specially modified materials on the basis of the proven Turcon® materials. Particular importance is attached to

the optimisation of friction and wear properties, even at high peripheral speeds.

Table I gives the materials available for use in Varilip® seals. Additional compounds have been developed for specific applications and these are available if required.

Table I Turcon® materials for Varilip®

Material, Applications, Properties	Code	Operating temp. °C	Mating surface hardness	MPa max.
Turcon® T25 Standard material with exceptional wear and friction characteristics. For lubricated or dry running. Glass fibre, lubricant Colour: Grey	T25	-60 to +200	Min. 55 HRc At low pressure and up to 4 m/s, min.45 HRc	2
Turcon® T40 For all lubricating and non-lubricating fluids. Used for medium hard shafts in applications where there is risk of shaft wear. Carbon fibre Colour: Grey	T40	-60 to +200	Min. 30 HRc	2
Turcon® T78 Particularly good running behaviour permits use with dry running or poor lubrication and in conjunction with soft shaft surfaces eg stainless steel shafts in food, pharmaceutical & chemical industries. Aromatic polymer. Colour: tan to dark brown	T78	-60 to +200	Min. 170 HB	0.2

Other Turcon® materials are available by using the relevant material code when ordering.

Seal case

Standard Varilip® seals are available with a choice of three stainless steel materials for the seal case, as shown in table II.

In cases where repeated temperature cycling occurs with large variations in operating temperature, it is preferred that the seal case materials are selected such that the coefficient of linear expansion is similar to the material of the housing into which the seal will be assembled, to minimise the potential for loss of the interference between the seal and the housing, and the resultant leakage or relative movement.

Table III shows a selection of materials which can be used for Varilip® PDR seals to achieve the most compatible seal to housing interface. Additional materials specific to individual applications may also be suitable, subject to satisfactory process testing.

Table II Casing materials

Medium	Material	Code
Oils, greases, air/gases, water, vapour, solvents, foodstuffs	Stainless steel Material No. 1.4301 AISI 304	1
Acids, caustics, seawater	Acid-resistant stainless steel Material No. 1.4436 AISI 316	2
	Acid-resistant stainless steel Material No. 1.4571 AISI 316 Ti	3*)

*) Only for type **A, C** and **D** up to max. 90 mm outside diameter.

Table III Housing materials

Housing	Preferred Seal Case	None-preferred Seal Case
Steel, cast iron	Low carbon steel	Stainless steel or titanium
Aluminium alloy, die cast aluminium, magnesium	Aluminium alloy	Stainless steel
Stainless steel	Stainless steel	Low carbon steel
Titanium	Titanium	Low carbon steel
Phosphor bronze	Phosphor bronze	Hastelloy C276

Highlighted materials are standard.



Internal gasket

For Varilip[®] seals, the material for the internal gasket should be specified with consideration of the fluid resistance and temperature regimes, in accordance with table IV. Varilip[®] PDR seals can be designed with no elastomer content for maximum fluid compatibility. In cases where an elastomer is used, either as the internal gasket or as the sealing mechanism for the seal outside diameter, a wide range of materials is available to suit the fluids, temperature ranges and other conditions, such as food grade approval.

Table IV Materials for gasket elastomers

Medium	Temperature	Material	Code
Air, water, oils, greases	Nitrile-Elastomer -30 to +110°C	NBR	N
Air, water, vapour, foodstuffs, alcohol	Ethylene-propylene-elastomer -60 to +150°C	EPDM	E
Air, water, oils, greases, solvents, acids, caustics	Fluoroelastomer -20 to +200°C	FKM	V



Operating Parameters

Speed

The graph in figure 5 is based upon DIN 3760 and shows the limiting surface speed envelopes for various elastomeric shaft seals. Results obtained from testing Varilip® PDR seals are superimposed. For general guidance, Varilip® Type A is suitable up to 30 m/s, whilst Types B, C, D, E & F should be limited to a maximum of 15m/s. The operating speed directly impacts the temperature generated by the seal and this is an important factor when considering the requirements for the sealing system. With specific designs, Varilip® PDR seals are in applications operating at surface speeds of 108 m/s and have been successfully tested in applications approaching 140 m/s. The actual limiting speed will be dependant upon the temperature, pressure, media, lubrication properties, heat dissipation and the shaft condition.

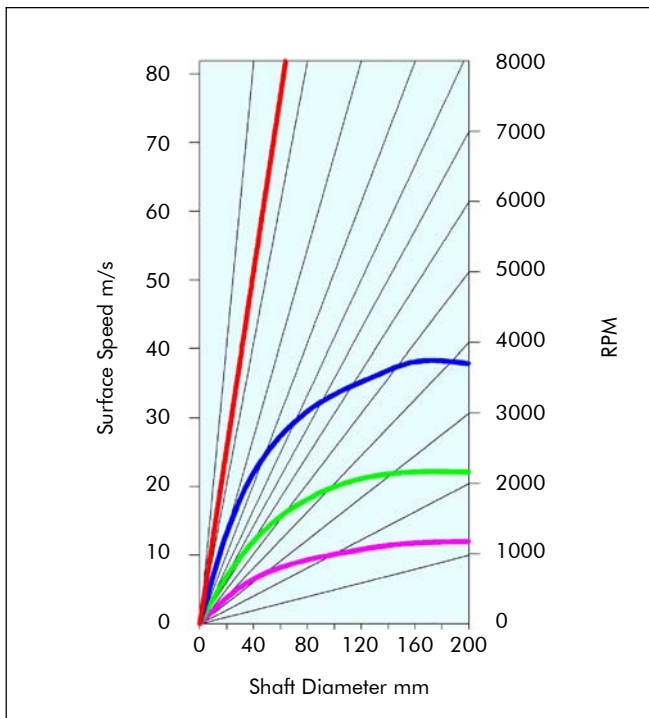

Figure 5 Surface speed as a function of shaft diameter and RPM

Table V Surface speed

General Recommended maximum Surface Speed		
Varilip® PDR (to date)		108 m/s
Fluoroelastomer		38 m/s
Silicone		38 m/s
Polyacrylic		22 m/s
Nitrile		12 m/s

Temperature

All Turcon® seals are capable of outstanding high and, perhaps more importantly, low temperature performance compared to elastomeric materials. For Varilip® seals the temperature limitation is controlled by the elastomer material selected for the internal gasket. Varilip® PDR seals can be designed without this limitation. The temperature capabilities given in figure 6 relate to the material itself and heat generation effects leading to higher localised temperatures than the bulk media or ambient level should be considered.

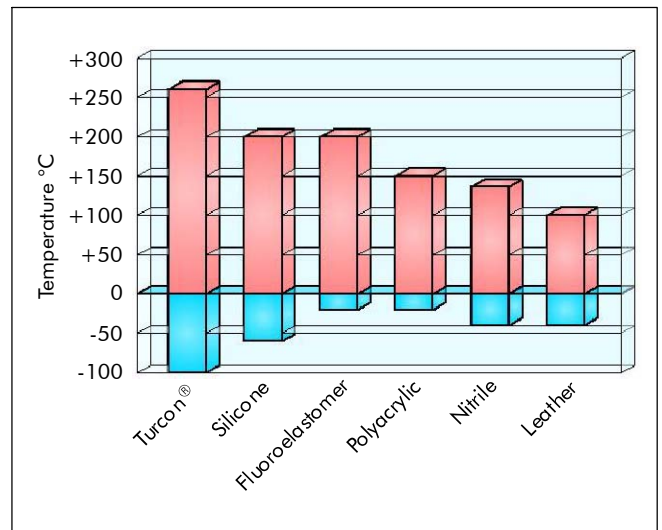

Figure 6 Maximum and minimum temperatures for different materials

Table VI Temperature

General Recommended minimum/maximum Temperature	
Filled PTFE	-100 to +260°C
Fluoroelastomer	-20 to +200°C
Silicone	-60 to +200°C
Polyacrylic	-20 to +150°C
Nitrile	-40 to +135°C
Leather	-40 to +100°C



Pressure

Varilip[®] Types A and B are suitable for pressures up to 0.5 MPa. Varilip[®] Type C provides increased lip thickness to cater for pressures up to 2 MPa whilst Varilip[®] Type D should be limited to 0.1 MPa. Varilip[®] PDR seals can be specifically designed to cater for higher pressures, depending upon other application considerations, particularly surface speed, temperature and life requirement. Varilip[®] PDR seals are used in applications with short pressure spikes up to 6 MPa.

Pressure heavily influences the contact force between the Turcon[®] lip and the shaft and consequently the heat generation. The following P x V values should only be used as a general guideline for Varilip[®].

For shaft diameters from 30mm to 170mm:

- Up to 1.5 (MPa x m/s) with good lubrication
- Up to 3.0 (MPa x m/s) with good lubrication and cooling
- Up to 10 (MPa x m/s) with very good lubrication and cooling or high temperature capability media.

For smaller shaft sizes these values should be reduced. For PV values outside these values the use of a Varilip[®] PDR is recommended.

Fluid Resistance

Turcon[®] consists of fully substituted carbon-carbon chains and the carbon-carbon and carbon-fluorine bonds are among the strongest known in organic chemistry. The outstanding physical and chemical properties of Turcon[®] can be attributed to these strong bonds. Within the constraints of any elastomer used in the seal construction, for either the internal gasket or outer diameter sealing, Varilip[®] seals are resistant to mineral acids, bases, common organic fluids and solvents. They are also unaffected by oxidation, ultraviolet radiation or ozone making them ideally suited for use in the chemical industry and applications requiring exposure to the atmosphere. Varilip[®] PDR can be designed without elastomer content for applications exposed to particularly aggressive media. A particular benefit is resistance to oil additives which have an adverse affect on many elastomers. Using Turcon[®] shaft seals allows the increased use of additives and hence a longer oil service life.

Lubricant Starvation

Turcon[®] shaft seals have the capability to run without lubricated for longer periods of time compared with elastomer shaft seals without adversely affecting the ultimate life. This not only allows them to be used in applications where the lubrication may be intermittent as a result of start up or other operating factors, but also allows their use as effective dirt, dust and powder seals. In one test Varilip[®] PDR seals were run dry for 100 hours at 16 m/s and then continuously sealed oil.



Power Consumption

Guide values for the torque and frictional power consumed by various types of Varilip® seal can be determined from figures 7 and 8. For specific applications where achieving a certain level of power consumption is critical to the operation of the equipment, Varilip® PDR seals can be designed and tested to demonstrate compliance with the requirement.

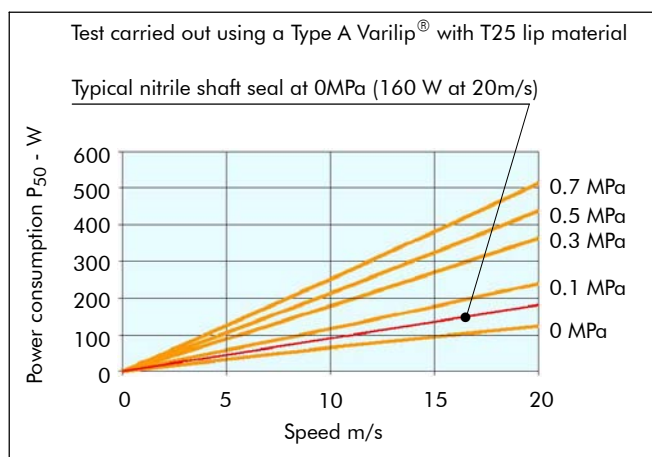

Figure 7 Power consumption on a 50 mm shaft

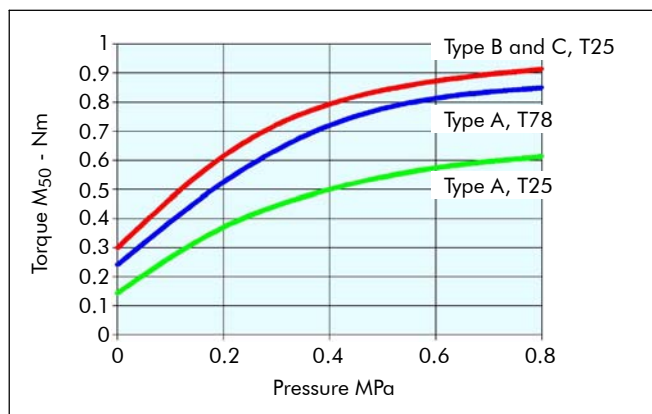

Figure 8 Torque on a 50 mm shaft

Guide values for other shaft diameters (d) can be approximated from the following formulae:

$$p \approx p_{50} \times (d/50) \text{ [W]}$$

and

$$M \approx M_{50} \times (d/50)^2 \text{ [Nm]}$$

Endurance

Turcon® rotary shaft seals can provide an extended service life compared with elastomer shaft seals. As with any seal, the life of a Varilip® seal is very dependant upon the specific operating parameters, but the following examples clearly illustrate the superior life achievable with these seals:

- A Varilip® PDR fitted as an engine crankshaft seal has completed over 1.75 million km (1.1 million miles) without leakage and both the shaft and seal were in excellent condition after this length of service. This was a known endurance vehicle and many seals are likely to have significantly exceeded this result.
- A Varilip® PDR fitted to a rotary vane compressor has been run for 23,000 hours without leakage and, more significantly for this particular application, has completed in excess of 500,000 start/stop cycles before the test was terminated.
- Varilip® seals have been tested on aircraft flap actuators to a simulated 50,000 take-off and landing cycles without leakage.
- Varilip® seals fitted to pneumatic swivels running unlubricated at 8 bar air pressure have exceeded service intervals of 13,000 hours.
- A Varilip® PDR has been run on a turbocharger fitted to a marine diesel engine. With surface speeds of 108m/s, seal life in excess of 4500 hours has been achieved.



■ Design Guidelines

Housing

Varilip[®] seals require an interference fit with the housing bore to provide both adequate sealing of this interface and to ensure that the seal remains in place when subjected to pressure, axial movement and induced torsion produced by the relative rotary motion of shaft to housing bore. The bore should be machined with an H8 diametric tolerance according to DIN 3760, ISO 6194/1 and ISO 16589/1 as reproduced in table VII. Varilip[®] PDR seals can be designed with a coating on the outer diameter, full rubber covering or an O-Ring fitted to either seal or housing bore to ensure good sealing of this interface. System design should also ensure that Varilip[®] seals are not pushed into bores that may have been previously scored by the assembly of another component, such as a bearing, selecting a larger seal outer diameter if necessary.

Varilip[®] PDR can also be designed to include discrete anti-rotation features, such as pins, lugs or axial clamping which, in conjunction with O-Ring sealing can be used in cases where frequent seal assembly and disassembly may otherwise damage the bore.

For Varilip[®] seals the bore should have a surface finish better than 10 μm Rmax, 6.3 μm Rz and 1.6 μm Ra. In cases where the housing bore is split resulting in an axial joint crossing the seal outer diameter, and in cases where meeting these surface finish requirements is not possible, it is recommended that a proprietary sealant or adhesive is used. Generally, Varilip[®] PDR can accommodate surface finishes up to 3.2 μm Ra.

Table VII Housing installation data

Bore diameter [mm]		Tolerance	
Over	To	H8 [mm]	
3	—	6	+ .018 -0
6	—	10	+ .022 -0
10	—	18	+ .027 -0
18	—	30	+ .033 -0
30	—	50	+ .039 -0
50	—	80	+ .046 -0
80	—	120	+ .054 -0
120	—	180	+ .063 -0
180	—	250	+ .072 -0
250	—	315	+ .081 -0
315	—	400	+ .089 -0

The bore depth and dimensions of the required lead in chamfer and corner radius are given in figure 9. The lead-in chamfer should be free from burrs and sharp corners.

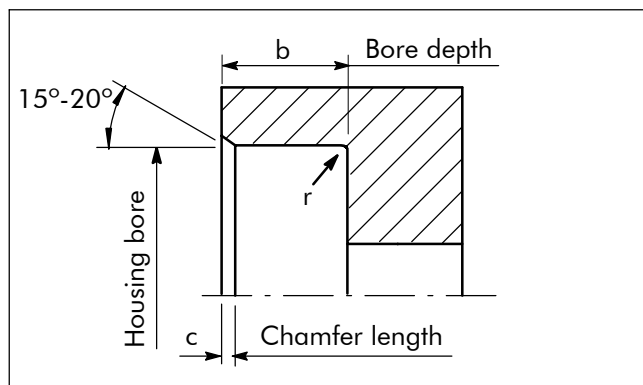

Figure 9 Housing design

Table VIII Housing design data

Seal width	Up to 10 [mm]	Over 10 [mm]
Min. bore depth (b)	b + 0.9	b + 1.2
Chamfer length (c)	0.70 to 1.00	1.20 to 1.50
Max. corner rad. (r)	0.50	0.75

Shaft

This should be machined to an h11 tolerance or better, according to Din 3760, ISO 6194/1 and ISO 16589/1 and reproduced in table IX. The surface finish should be prepared by plunge grinding to avoid any machining leads which may act with the shaft rotation to facilitate leakage. Recommended surface finishes for Varilip[®] are 0.1 to 0.4 μm Ra and 0.63 to 2.5 μm Rz, whilst Varilip[®] PDR generally allow this to be relaxed to 0.2 to 0.6 μm Ra and 0.8 to 2.5 μm Ry or 1.0 to 2.0 μm Rz.



Table IX Shaft installation data

Shaft diameter [mm]		Tolerance	
Over	To	h11 [mm]	
3	—	6	+0 -.075
6	—	10	+0 -.090
10	—	18	+0 -.110
18	—	30	+0 -.130
30	—	50	+0 -.160
50	—	80	+0 -.190
80	—	120	+0 -.220
120	—	180	+0 -.250
180	—	250	+0 -.290
250	—	315	+0 -.320
315	—	400	+0 -.360

A shaft hardness in excess of 55 HRC is generally recommended for Varilip®, although lower values are permissible depending upon the pressure, speed and sealing lip material used (refer to materials section).

With specific design considerations, Varilip® PDR seals can be run on much softer shafts, including SG Iron and low carbon steels. Titanium shafts should be avoided unless nitrided. Shafts with good chrome, nickel or zinc plating, properly finished are acceptable. Certain ceramic coatings can also be used, although some grades have been proven to result in an aggressive wear of the sealing lip. In certain applications it may not be possible to provide a shaft with the necessary hardness, surface finish and corrosion resistance. Fitting a wear sleeve onto the shaft can solve this problem such that if wear should occur, only the sleeve need then be replaced. The surface finish of the sleeve should be as outlined above and consideration should be given to adequate heat dissipation and effective sealing of the interface between the wear sleeve and the shaft.

When installing Varilip® seals, careful handling is important in order to avoid damaging the sealing lip. If the seal is installed from the back, radii or lead-in chamfers must be machined on the end of the shaft, free from burrs, sharp corners or rough machining marks, as shown in figure 10. When installing the seal with the lip against the shaft end, a lead-in chamfer is required whose smallest diameter is smaller than the unstressed diameter of the sealing lip as shown in figure 11. Table X shows guide values for this. Preferable is the use of an installation cone, as shown in figure 12, where the seal can be fitted onto the cone before being located on the shaft to ensure correct orientation of the sealing lip.

It is recommended that as shallow an angle as practical be adopted within the range given, particularly for Varilip® Type C and F.

Table X Shaft lead in chamfer

d ₁ [mm]	d ₁ - d ₃ [mm]
< 10	1.5
10 - 20	2.0
20 - 30	2.5
30 - 40	3.0
40 - 50	3.5
50 - 70	4.0
70 - 95	4.5
95 - 130	5.5
130 - 240	7.0
240 - 300	11.0

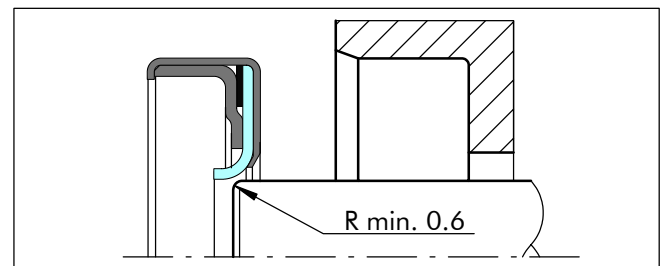

Figure 10 Installation of the sealing lip with the back to the shaft for pressurised application

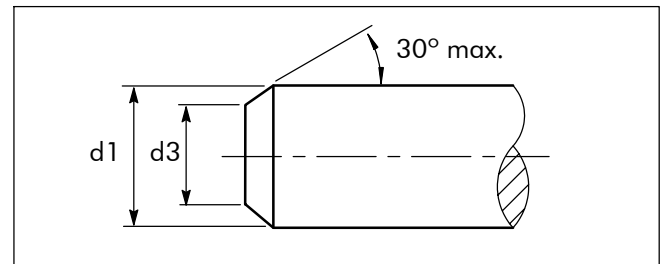

Figure 11 Shaft lead in chamfer

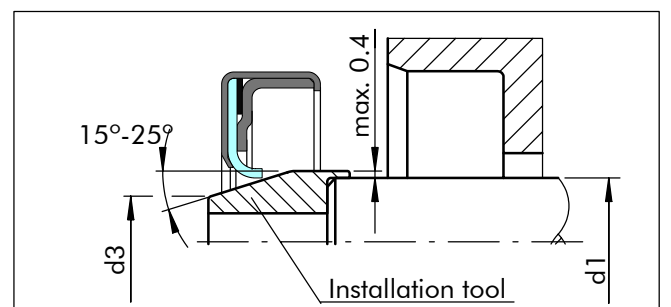

Figure 12 Fitting the sealing lip using an installation tool



Eccentricity

The graph in figure 13 is reproduced from DIN 3760 and shows the maximum recommended operating envelope for silicone, nitrile, polyacrylic and fluoroelastomer seals. Varilip[®] seals have a low interference with the shaft and to minimise the risk of leakage and increased wear rates, the levels of eccentricity should be kept within the limits shown. In order to achieve a uniform radial load of the sealing lip on the shaft, the best possible coaxiality, or static offset, should be maintained between the housing bore and the shaft, as shown in figure 14. Varilip[®] PDR seals can, depending upon the application, be specifically designed to accommodate very high levels of eccentricity. Levels of 0.56mm TIR on a 67mm diameter shaft running at 3000 rpm have successfully sealed for in excess of 500 hours.

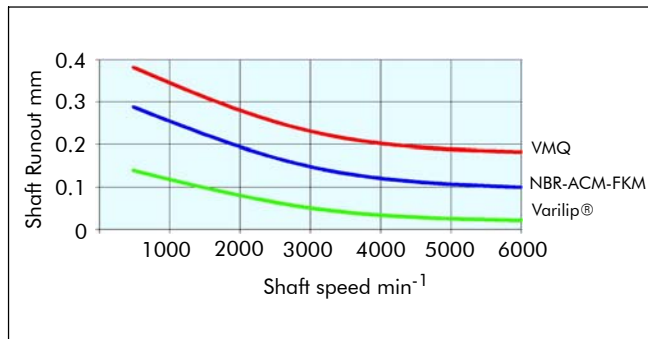

Figure 13 Dynamic eccentricity capability

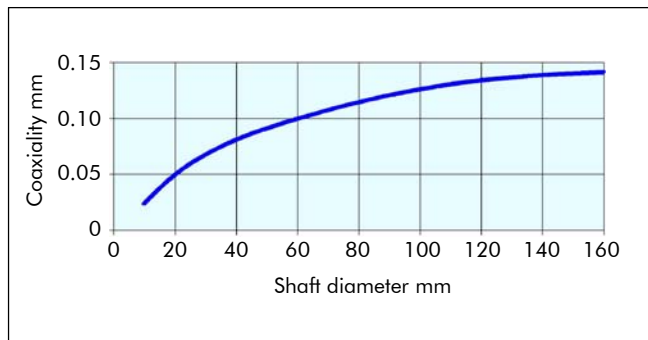

Figure 14 Coaxiality tolerance

Leakage expectation

Achieving absolute tightness between a sealing mechanism and a relatively moving surface is not possible. It is important that the level of permissible leakage for each application is determined as part of the specification for the sealing solution. Generally a Varilip[®] seal can be expected to provide at least the same level of sealing as that achieved with a good quality elastomer shaft seal, assuming all operating parameters and the combination of them are within acceptable limits. Varilip[®] PDR seals can be specifically designed to satisfy very stringent requirements on seal tightness and previous applications have included cases where practically zero leakage has been achieved.

Heat Generation Considerations

All Varilip[®] seals are designed to contact the shaft surface during operation. The contact force between the sealing lip and the shaft will depend upon the seal design used and the application details, but in all cases a temperature increase due to the presence of the seal can be expected. Where this increase is likely to be significant, either due to high pressures, surface speeds or poor lubrication, or due to the surrounding equipment or media being particularly sensitive to temperature rises, consideration should be given to methods of reducing the level of generated heat. This can be achieved through increases in localised cooling, improved lubrication, efficient heat transfer mechanisms and the use of a Varilip[®] PDR seal specifically designed to give low levels of heat generation.



Shaft Wear

Whilst Turcon® is inherently a low friction material, all Varilip® seals are designed to contact the shaft surface during operation and a seal contact band will be evident in the majority of applications. With correct seal specification and operating conditions, shaft wear should be limited to a light polishing, but factors such as over pressure, contamination, eccentricity and others can result in more significant wear. As part of the system design, consideration should be given to the level of shaft wear permissible within a set operating period and therefore the benefits of measures intended to reduce the rate of wear, such as shaft coatings, can be analysed in relation to their additional cost.

■ Packaging

Varilip® seals are supplied wrapped together in short stacks. Varilip® PDR have a higher level of diametric interference between the sealing lip and the shaft and to ease the assembly these seals are supplied on mandrels to hold the sealing lip just below final shaft size. Alternative packaging arrangements, such as blister packing, long mandrels with multiple seals per mandrel, individually boxed, re-usable kanban boxes and others are available on request for specific applications. Seals can also be supplied on transport sleeves which have the assembly aid included in them, such that fitting the seal does not require a separate tool. This is of particular benefit if the seal is to be supplied as a spares item and fitted in a number of remote locations.

■ Fitting Instructions

Investigation of premature failures has shown that a significant proportion are as a result of inappropriate installation techniques. However, by observing the following guidelines, such failures can be avoided:

- Assembly sleeves and fitting tools should be regularly checked for signs of damage.
- When supplied on mandrels the seals should not be removed from the mandrel until immediately prior to fitting. Seals supplied on cardboard mandrels should be removed in the direction such that the spiral paper overlay of the mandrel is not lifted.
- Varilip® seals may be pre-lubricated with the system fluid prior to assembly if initial torque levels need to be minimised. Varilip® PDR seals should be assembled on to the shaft in an unlubricated (dry) condition to avoid contamination of the hydrodynamic feature.
- Rubber coated seals should be assembled into the housing using the system fluid as a lubricant on their outer diameter.

- Care should be taken not to damage the outer diameter surface of the seal, whether this is coated in sealant, rubber covered or a plain metal case.
- Seals should be pressed squarely into the housing with the pressing-in force applied as close as possible to the outside diameter of the seal.
- If the seal contains a hydrodynamic feature on the sealing lip, ensure that it is correctly oriented in relation to the shaft's direction of rotation.
- Normal practice is to install the seal with the lip facing the medium to be sealed (the seal is reversed only when it becomes more important to exclude a medium than to retain it).
- Proprietary sealants or adhesives may be used for improved sealing of the outer diameter in critical applications or for seal retention purposes. However, this should be avoided if the Varilip® PDR seal has been supplied pre-coated with a sealant on the outer diameter as chemical compatibility issues may result.
- Varilip® seals have widths designed in accordance with ISO 6194/1 and ISO 16589 so as to ensure square seating of the seal in the housing bore. However narrower seals can be accommodated if assembly tooling, axial clamping or a retention circlip is used. Recommended tooling aids for satisfactory seal assembly are shown in figure 15 and 16.

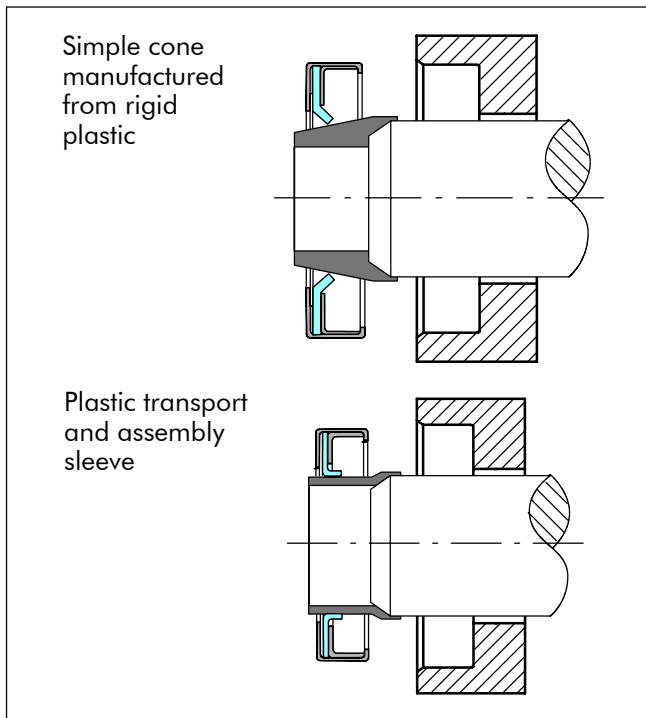

Figure 15 Assembly techniques

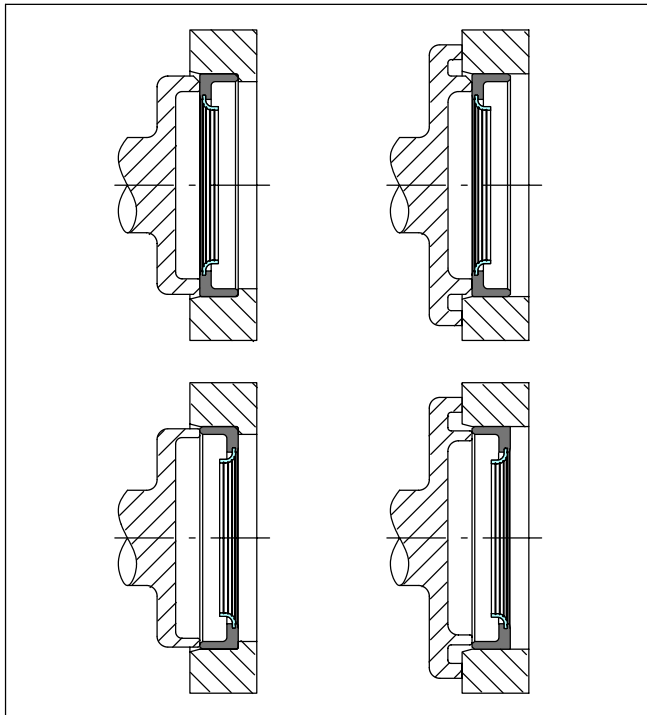

Figure 16 Assembly techniques



Installation Recommendations

The following diagrams show installation recommendations in respect to seal retention under pressure conditions.

Post Installation Recommendations:

- If painting, be sure to mask the seal. Avoid getting paint on the lip, or the shaft where the lip rides. Also, mask any vents or drain holes so they will not become clogged. Be sure to remove masks before operating unit.
- If paint is to be baked, or the mechanism is otherwise subjected to heat, seals should not be heated to temperatures higher than their materials can tolerate.
- In cleaning or testing, do not subject seals to any fluids or pressures other than those for which the seal has been specified.

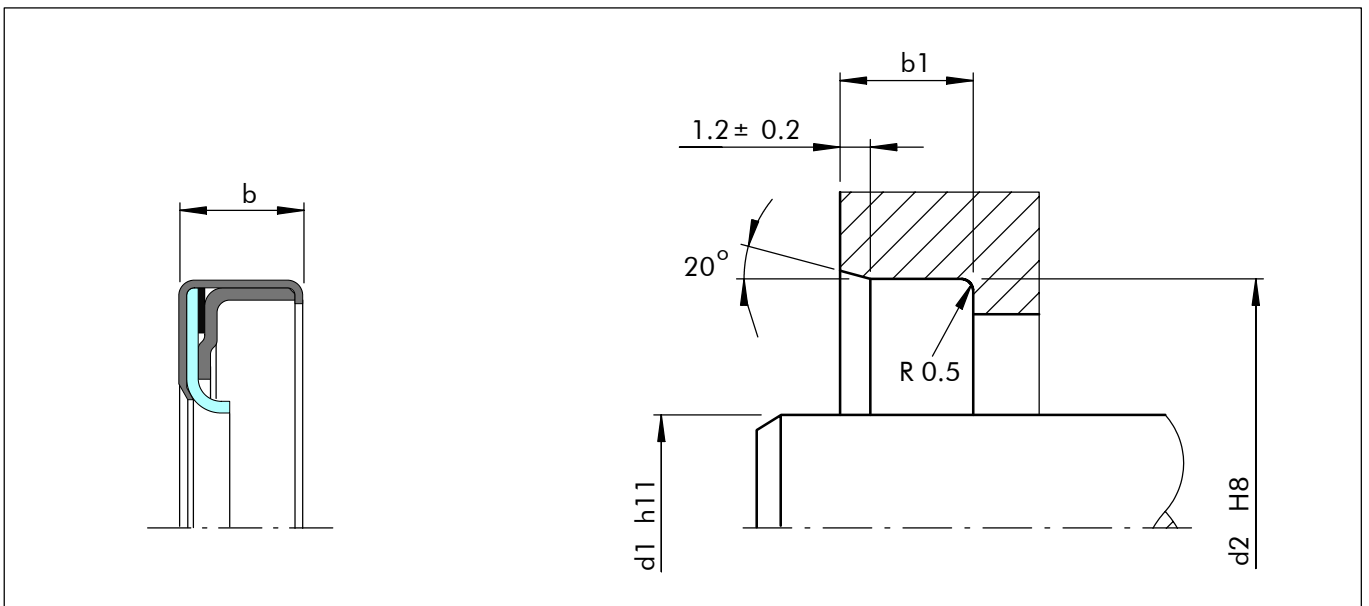

Figure 17 Installation drawing for pressure up to 0.2 MPa

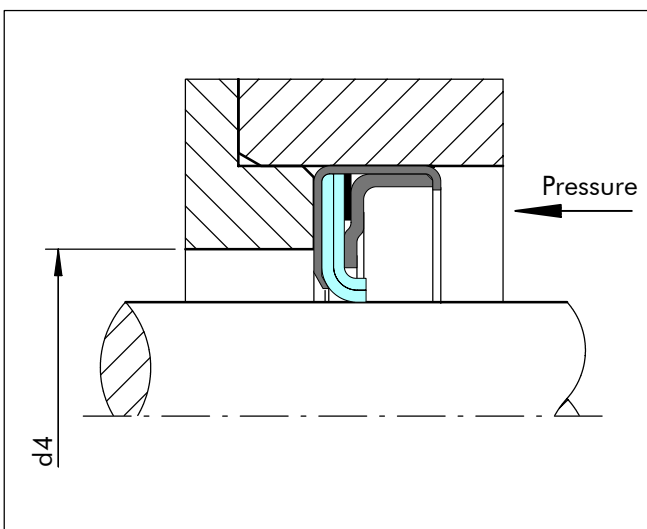

Figure 18 Installation for pressure from 0.2 MPa up to 2 MPa

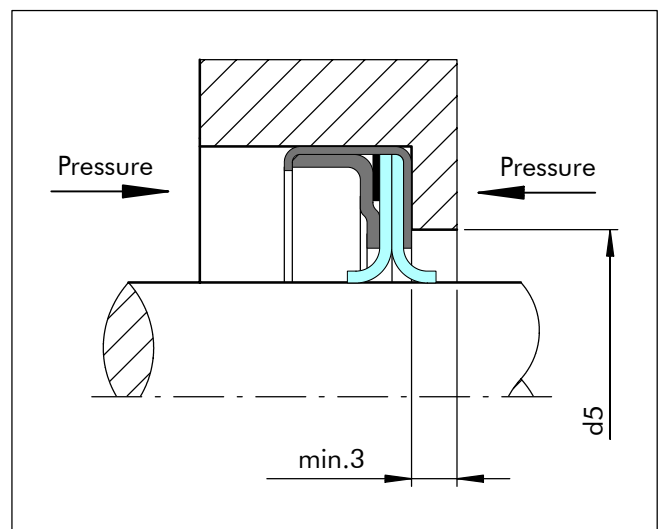

Figure 19 Installation type D



■ Selection Guide

If a bespoke, integrated or customised sealing solution is required, please complete the questionnaire on page 23 and send it to your local Busak+Shamban sales office to allow a specific proposal to be prepared. If it is preferred to use a standard range product, please follow the flow chart below to determine the product type recommended:

Note: This guide considers pressure and surface speed in isolation. Consideration should also be given to the PV value, as explained on page 9

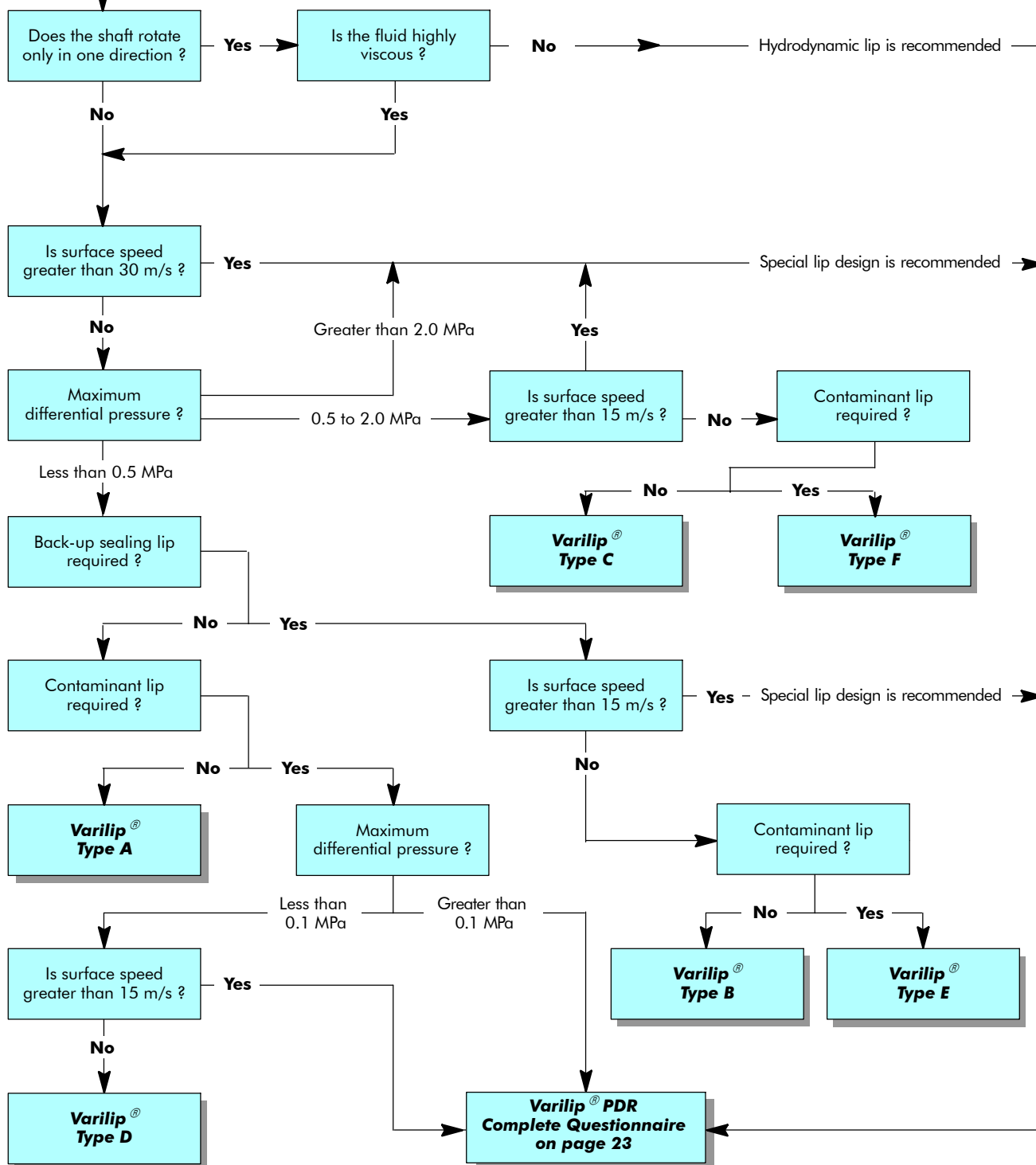



Table XI Varilip® Standard Sizes

Sizes			Part no.	b ₁ minimum [mm]	d ₄ maximum [mm]	d ₅ minimum [mm]
d ₁ [mm]	d ₂ [mm]	b [mm]				
6	16	7	TP_100060	7.3	10	9.6
6	22	7	TP_200060	7.3	10	9.6
7	22	7	TP_100070	7.3	11	10.6
8	22	7	TP_100080	7.3	12	11.6
8	24	7	TP_200080	7.3	12	11.6
9	22	7	TP_100090	7.3	13	12.6
9	24	7	TP_200090	7.3	13	12.6
9	26	7	TP_300090	7.3	13	12.6
10	22	7	TP_100100	7.3	14	13.6
10	24	7	TP_200100	7.3	14	13.6
10	25	7	TP_300100	7.3	14	13.6
10	26	7	TP_400100	7.3	14	13.6
11	22	7	TP_100110	7.3	15	14.6
11	26	7	TP_200110	7.3	15	14.6
12	22	7	TP_100120	7.3	16	15.6
12	24	7	TP_200120	7.3	16	15.6
12	25	7	TP_300120	7.3	16	15.6
12	28	7	TP_400120	7.3	16	15.6
12	30	7	TP_500120	7.3	16	15.6
14	24	7	TP_100140	7.3	18	17.6
14	28	7	TP_200140	7.3	18	17.6
14	30	7	TP_300140	7.3	18	17.6
14	35	7	TP_400140	7.3	18	17.6
15	26	7	TP_100150	7.3	19	18.6
15	30	7	TP_200150	7.3	19	18.6
15	32	7	TP_300150	7.3	19	18.6
15	35	7	TP_400150	7.3	19	18.6
16	28	7	TP_100160	7.3	20	19.6
16	30	7	TP_200160	7.3	20	19.6
16	32	7	TP_300160	7.3	20	19.6
16	35	7	TP_400160	7.3	20	19.6
17	28	7	TP_100170	7.3	21	20.6
17	30	7	TP_200170	7.3	21	20.6
17	32	7	TP_300170	7.3	21	20.6
17	35	7	TP_400170	7.3	21	20.6
17	40	7	TP_500170	7.3	21	20.6
18	30	7	TP_100180	7.3	22	21.6
18	32	7	TP_200180	7.3	22	21.6
18	35	7	TP_300180	7.3	22	21.6
18	40	7	TP_400180	7.3	22	21.6

Sealing lips may, in some cases, protrude beyond the edge of the seal case.
 Sizes printed in **bold** are preferred. Other sizes are available on request.



Turcon[®] Rotary Shaft Seals

Sizes			Part no.	b ₁ minimum [mm]	d ₄ maximum [mm]	d ₅ minimum [mm]
d ₁ [mm]	d ₂ [mm]	b [mm]				
20	30	7	TP_100200	7.3	24	23.6
20	32	7	TP_200200	7.3	24	23.6
20	35	7	TP_300200	7.3	24	23.6
20	40	7	TP_400200	7.3	24	23.6
20	47	7	TP_500200	7.3	24	23.6
22	32	7	TP_100220	7.3	26	25.6
22	35	7	TP_200220	7.3	26	25.6
22	40	7	TP_300220	7.3	26	25.6
22	47	7	TP_400220	7.3	26	25.6
24	35	7	TP_100240	7.3	28	27.6
24	37	7	TP_200240	7.3	28	27.6
24	40	7	TP_300240	7.3	28	27.6
24	47	7	TP_400240	7.3	28	27.6
25	35	7	TP_100250	7.3	29	28.6
25	40	7	TP_200250	7.3	29	28.6
25	42	7	TP_300250	7.3	29	28.6
25	47	7	TP_400250	7.3	29	28.6
25	52	7	TP_500250	7.3	29	28.6
26	37	7	TP_100260	7.3	30	29.6
26	42	7	TP_200260	7.3	30	29.6
26	47	7	TP_300260	7.3	30	29.6
28	40	7	TP_100280	7.3	32	31.6
28	47	7	TP_200280	7.3	32	31.6
28	52	7	TP_300280	7.3	32	31.6
30	40	7	TP_100300	7.3	34	33.6
30	42	7	TP_200300	7.3	34	33.6
30	47	7	TP_300300	7.3	34	33.6
30	52	7	TP_400300	7.3	34	33.6
30	62	7	TP_500300	7.3	34	33.6
32	45	7	TP_100320	7.3	36	35.6
32	45	8	TP_200320	8.3	36	35.6
32	47	7	TP_300320	7.3	36	35.6
32	47	8	TP_400320	8.3	36	35.6
32	52	7	TP_500320	7.3	36	35.6
32	52	8	TP_600320	8.3	36	35.6
35	47	7	TP_100350	7.3	39	38.6
35	50	7	TP_200350	7.3	39	38.6
35	50	8	TP_300350	8.3	39	38.6
35	52	7	TP_400350	7.3	39	38.6
35	52	8	TP_500350	8.3	39	38.6
35	55	8	TP_600350	8.3	39	38.6
35	62	7	TP_700350	7.3	39	38.6

Sealing lips may, in some cases, protrude beyond the edge of the seal case.
 Sizes printed in **bold** are preferred. Other sizes are available on request.



Sizes			Part no.	b ₁ minimum [mm]	d ₄ maximum [mm]	d ₅ minimum [mm]
d ₁ [mm]	d ₂ [mm]	b [mm]				
36	47	7	TP_100360	7.3	40	39.6
36	50	7	TP_200360	7.3	40	39.6
36	52	7	TP_300360	7.3	40	39.6
36	62	7	TP_400360	7.3	40	39.6
38	52	7	TP_100380	7.3	42	41.6
38	55	7	TP_200380	7.3	42	41.6
38	55	8	TP_300380	8.3	42	41.6
38	58	8	TP_400380	8.3	42	41.6
38	62	7	TP_500380	7.3	42	41.6
38	62	8	TP_600380	8.3	42	41.6
40	52	7	TP_100400	7.3	44	43.6
40	55	7	TP_200400	7.3	44	43.6
40	55	8	TP_300400	8.3	44	43.6
40	62	7	TP_400400	7.3	44	43.6
40	62	8	TP_500400	8.3	44	43.6
40	72	7	TP_600400	7.3	44	43.6
42	55	8	TP_100420	8.3	46	45.6
42	62	8	TP_200420	8.3	46	45.6
42	72	8	TP_300420	8.3	46	45.6
45	60	8	TP_100450	8.3	49	48.6
45	62	8	TP_200450	8.3	49	48.6
45	65	8	TP_300450	8.3	49	48.6
45	72	8	TP_400450	8.3	49	48.6
48	62	8	TP_100480	8.3	52	51.6
48	72	8	TP_200480	8.3	52	51.6
50	65	8	TP_100500	8.3	54	53.6
50	68	8	TP_200500	8.3	54	53.6
50	72	8	TP_300500	8.3	54	53.6
50	80	8	TP_400500	8.3	54	53.6
52	68	8	TP_100520	8.3	56	55.6
52	72	8	TP_200520	8.3	56	55.6
55	70	8	TP_100550	8.3	59	58.6
55	72	8	TP_200550	8.3	59	58.6
55	80	8	TP_300550	8.3	59	58.6
55	85	8	TP_400550	8.3	59	58.6
56	70	8	TP_100560	8.3	60	59.6
56	72	8	TP_200560	8.3	60	59.6
56	80	8	TP_300560	8.3	60	59.6
56	85	8	TP_400560	8.3	60	59.6
58	72	8	TP_100580	8.3	62	61.6
58	80	8	TP_200580	8.3	62	61.6

Sealing lips may, in some cases, protrude beyond the edge of the seal case.
 Sizes printed in **bold** are preferred. Other sizes are available on request.



Turcon[®] Rotary Shaft Seals

Sizes			Part no.	b ₁ minimum [mm]	d ₄ maximum [mm]	d ₅ minimum [mm]
d ₁ [mm]	d ₂ [mm]	b				
60	75	8	TP_100600	8.3	64	63.6
60	80	8	TP_200600	8.3	64	63.6
60	85	8	TP_300600	8.3	64	63.6
60	90	8	TP_400600	8.3	64	63.6
62	85	10	TP_100620	10.3	68	66.4
62	90	10	TP_200620	10.3	68	66.4
63	85	10	TP_100630	10.3	69	67.4
63	90	10	TP_200630	10.3	69	67.4
65	85	10	TP_100650	10.3	71	69.4
65	90	10	TP_200650	10.3	71	69.4
65	100	10	TP_300650	10.3	71	69.4
68	90	10	TP_100680	10.3	74	72.4
68	100	10	TP_200680	10.3	74	72.4
70	90	10	TP_100700	10.3	76	74.4
70	95	10	TP_200700	10.3	76	74.4
70	100	10	TP_300700	10.3	76	74.4
72	95	10	TP_100720	10.3	78	76.4
72	100	10	TP_200720	10.3	78	76.4
75	95	10	TP_100750	10.3	81	79.4
75	100	10	TP_200750	10.3	81	79.4
78	100	10	TP_100780	10.3	84	82.4
80	100	10	TP_100800	10.3	86	84.4
80	110	10	TP_200800	10.3	86	84.4
85	110	12	TP_100850	12.4	91	89.4
85	120	12	TP_200850	12.4	91	89.4
90	110	12	TP_100900	12.4	96	94.4
90	120	12	TP_200900	12.4	96	94.4
95	120	12	TP_100950	12.4	101	99.4
95	125	12	TP_200950	12.4	101	99.4
100	120	12	TP_101000	12.4	106	104.4
100	125	12	TP_201000	12.4	106	104.4
100	130	12	TP_301000	12.4	106	104.4
105	130	12	TP_101050	12.4	111	109.4
105	140	12	TP_201050	12.4	111	109.4
110	130	12	TP_101100	12.4	116	114.4
110	140	12	TP_201100	12.4	116	114.4
115	140	12	TP_101150	12.4	121	119.4
115	150	12	TP_201150	12.4	121	119.4
120	150	12	TP_101200	12.4	126	124.4
120	160	12	TP_201200	12.4	126	124.4
125	150	12	TP_101250	12.4	131	129.4
125	160	12	TP_201250	12.4	131	129.4

Sealing lips may, in some cases, protrude beyond the edge of the seal case.
 Sizes printed in **bold** are preferred. Other sizes are available on request.



Sizes			Part no.	b ₁ minimum [mm]	d ₄ maximum [mm]	d ₅ minimum [mm]
d ₁ [mm]	d ₂ [mm]	b [mm]				
130	160	12	TP_101300	12.4	136	134.4
130	170	12	TP_201300	12.4	136	134.4
135	170	12	TP_101350	12.4	141	139.4
140	170	15	TP_101400	15.4	148	147.0
145	175	15	TP_101450	15.4	153	152.0
150	180	15	TP_101500	15.4	158	157.0
160	190	15	TP_101600	15.4	168	167.0
170	200	15	TP_101700	15.4	178	177.0

Sealing lips may, in some cases, protrude beyond the edge of the seal case.
 Sizes printed in **bold** are preferred. Other sizes are available on request.

Ordering example

Varilip®, type A

Shaft diameter d₁ = 30 mm

Outside diameter d₂ = 47 mm

Width b = 7 mm

Table XI: Part no. TP_300300

The material is selected from Tables I, II and IV.

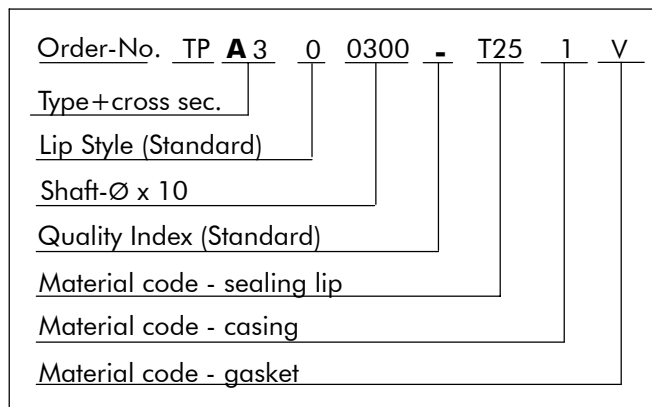

Order as: TPA300300-T251V

Type: A, B, C, D, E or F
 - refer to Product Range section

Cross Section: 1,2,3,4,5,6 or 7
 - refer to Table of Sizes

Lip Style: 0 (Std)

Shaft x 10: Refer to Table of Sizes

Quality Index: - for standard parts

Lip Material: refer to Materials section

Case Material: refer to Materials section

Gasket Material: refer to Materials section

Turcon® Rotary Shaft Seals

Technical and Purchasing Questionnaire



Company name					Agent/Salesman	
Address					Date	
Company products						
Application						
Contacts	Name	Title	Telephone	Fax	E-mail	
Technical						
Purchasing						

Technical details Where available a sample or drawing of an existing seal is helpful but insufficient for a viable design to be produced unless accompanied by the following information include installation drawing or scheme wherever possible.

Shaft			
Diameter, with tolerances			mm
Speed range	Maximum:	Typical:	Minimum: RPM
Direction of rotation (when viewed from air/low pressure side)	Clockwise <input type="checkbox"/>		Anti-clockwise <input type="checkbox"/> Bi-directional <input type="checkbox"/>
Material and treatment			
Surface roughness	$\mu\text{m Rz}$	$\mu\text{m Ra}$	
Hardness	HRc		
Dynamic eccentricity	mm TIR		
Static housing-to-shaft offset	mm centre to centre		
Axial movement and frequency	mm per		
Shaft type at sealing point	Solid <input type="checkbox"/>	Hollow <input type="checkbox"/>	Sleeve <input type="checkbox"/> Thickness <input type="checkbox"/> mm

Housing			
Diameter, with tolerances			mm
Depth of recess			mm
Speed range	Maximum:	Typical:	Minimum: RPM
Direction of rotation (when viewed from air/low pressure side)	Clockwise <input type="checkbox"/>		Anti-clockwise <input type="checkbox"/> Bi-directional <input type="checkbox"/>
Housing type	Axially split (split line will bisect seal OD) <input type="checkbox"/>		Homogeneous (no split line) <input type="checkbox"/>
Material and treatment			
Surface roughness	$\mu\text{m Rz}$	$\mu\text{m Rmax}$	$\mu\text{m Ra}$
Hardness	HRc		

Environment	
Type of fluid to be retained	
Fluid level relative to shaft centreline	
Shaft orientation during normal operation	Horizontal <input type="checkbox"/> Vertical <input type="checkbox"/>
Any other media seal may contact	Dust/dirt <input type="checkbox"/> Water splash <input type="checkbox"/> Other: _____
Working temperature	°C
Maximum and minimum temperatures	°C
Maximum and minimum pressure differential	Bar Cycle Rate
Maximum test pressure	Bar
Is seal subject to pressure without shaft rotation	Yes <input type="checkbox"/> No <input type="checkbox"/>

Purchasing details Note that this information will have an effect on the design solution offered. If actual data is unknown, please use estimations.

Drawing number (if available)			
Would a test programme be necessary	B+S <input type="checkbox"/> Customer <input type="checkbox"/> No <input type="checkbox"/>	Life Required	
Type of release	Aerospace <input type="checkbox"/> Defence <input type="checkbox"/> Industrial <input type="checkbox"/>	Specification	
Annual usage		Proportion we could expect	
Rate of call off		Supply commencement date	
Prototype quantity		Date prototypes required	



For further information:

Europe	Telephone
AUSTRIA - Vienna	+43 (1) 4 06 47 33
BELGIUM - Dion-Valmont	+32 (10) 22 57 50
BULGARIA - Rousse	+359 (82) 27 11 75
CZECH REPUBLIC - Rakovnik	+420 (313) 52 91 11
DENMARK - Hillerød	+45 (48) 22 80 80
FINLAND - Vantaa	+358 (9) 8 25 61 10
FRANCE - Sartrouville	+33 (1) 30 86 56 00
GERMANY - Stuttgart	+49 (711) 7 86 40
HOLLAND - Barendrecht	+31 (10) 2 92 21 11
ITALY - Livorno	+39 (0586) 22 61 11
LUXEMBOURG - Dion-Valmont	+32 (10) 22 57 50
NORWAY - Oslo	+47 (22) 64 60 80
POLAND - Warsaw	+48 (22) 8 63 30 11
SPAIN - Madrid	+34 (91) 7 10 57 30
SWEDEN - Jönköping	+46 (36) 34 15 00
SWITZERLAND - Crissier	+41 (21) 6 31 41 11
UNITED KINGDOM - Solihull	+44 (121) 7 44 12 21

For all other countries in Europe, Africa and the Near East, please contact:

Busak+Shamban S.A. Division R.G. Export.
 Route Sous-Riette 29, 1023 Crissier, Switzerland
 Telephone +41 (21) 6 31 41 11, Fax +41 (21) 6 31 41 45
 RGBSExport@busakshamban.com

America	Telephone
AMERICAS - Fort Wayne	+1 (260) 7 49 96 31
BRAZIL - Sao Paulo	+55 (11) 33 71 25 70
CANADA - Ontario	+1 (416) 2 13 94 44
MEXICO - Mexico D.F.	+52 (55) 53 85 05 86
USA, Midwest - Lombard	+1 (630) 2 68 99 15
USA, South - N. Charleston	+1 (843) 7 47 76 56
USA, Southwest - Houston	+1 (713) 4 61 34 95
USA, West - Torrance	+1 (310) 3 71 10 25

Asia	Telephone
CHINA - Hong Kong	+852 (2366) 91 65
INDIA - Bangalore	+91 (80) 6 55 51 57
JAPAN - Tokyo	+81 (35) 6 10 18 11
KOREA - Gyunggi-Do	+82 (31) 3 86 32 83
TAIWAN - Taichung	+886 (4) 23 58 00 82
SINGAPORE and all other countries in Asia	+65 (6293) 25 00

www.busakshamban.com

