

JF/JFL

3-PIECE, FEMALE

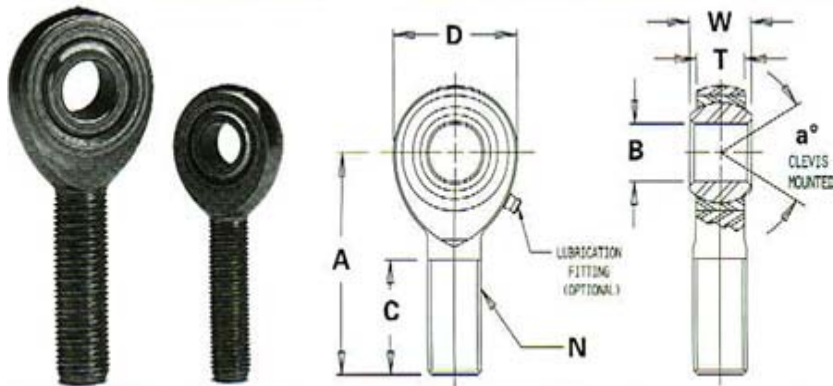

MATERIALS

BALL	BODY
52100 Steel Rc 56 MIN. HARD CHROME PLATED	LOW CARBON STEEL ZINC PLATED CHROMATE TREATED
LINER	
TEFLON FABRIC	

MALE ROD ENDS		B DIA.	D DIA.	W WIDTH	T WIDTH	BALL DIA.	A LGTH	N THD.	C LGTH	E DIA.	F FLAT	a MIS. ANGLE	ULT. STATIC RADIAL LOAD (lbs)	APPROX. WEIGHT (lbs)
RIGHT HAND PART NO.	LEFT HAND PART NO.	+0.0015 -0.0005	+0.010 -0.010	+0.000 -0.005	+0.015 -0.015	REF.	+0.015 -0.015	UNF 2B	+0.062 -0.031	+0.010 -0.010	+0.010 -0.010	REF.		
JF2*	JFL2*	.1250	.500	.250	.187	.312	.812	6-32 UNC	.437	.312	.250	16	1,210	.019
JF3	JFL3	.1900	.625	.312	.250	.437	1.062	10-32	.500	.406	.312	13	1,624	.04
JF4	JFL4	.2500	.750	.375	.281	.500	1.312	1/4-28	.687	.469	.375	16	2,545	.06
JF5	JFL5	.3125	.875	.437	.344	.625	1.375	5/16-24	.687	.500	.437	14	3,200	.09
JF6	JFL6	.3750	1.000	.500	.406	.719	1.625	3/8-24	.812	.687	.562	12	3,950	.15
JF7	JFL7	.4375	1.125	.562	.437	.812	1.812	7/16-20	.937	.750	.625	14	4,300	.20
JF8	JFL8	.5000	1.312	.625	.500	.937	2.125	1/2-20	1.062	.875	.750	12	6,700	.33
JF10	JFL10	.6250	1.500	.750	.562	1.125	2.500	5/8-18	1.375	1.000	.875	16	7,400	.48
JF12	JFL12	.7500	1.750	.875	.687	1.312	2.875	3/4-16	1.562	1.125	1.000	14	11,550	.72
JF16**	JFL16**	1.000	2.750	1.375	1.000	1.875	4.125	1-1/4-12	2.125	1.625	1.500	17	43,555	2.125
JF16-1**	JFL16-1**	1.000	2.750	1.375	1.000	1.875	4.125	1-14	2.125	1.625	1.500	17	43,555	2.410
JF16-2**	JFL16-2**	1.000	2.750	1.375	1.000	1.875	4.125	1-12	2.125	1.625	1.500	17	43,555	2.410

*GREASE FITTINGS & PTFE LINERS NOT AVAILABLE.

**TOLERANCE VARIATIONS: "D", "A" ARE +/- .020

BALL	BODY
52100STEEL Rc. 56 MIN. HARD RD CHROME PLATED	LOW CARBON STEEL ZINC PLATED CHROMEATE TREATED

RACE
STEEL ALLOY, HEAT TREATED ZINC PLATED, CHROMATE TREATED LOW CARBON STEEL: PTFE LINERS & NO. 2 SERIES

NOTES: FOR GREASE FITTINGS ADD "Z" TO SUFFIX
FOR STUDS ADD "Y" TO SUFFIX
FOR TEFLON LINER ADD "T" TO SUFFIX.

EXAMPLE: JF6Z

EXAMPLE: JF5Y

EXAMPLE: JFX12T